

**A.B.A.T.E. of**  
*Dedicated to*  
*Freedom of the Road!*



**Oregon, Inc.**  
*Let Those Who*  
*Ride Decide!*

---

**JULY 1994 NEWSLETTER** — edited by Gordon Hieronimus N.E. Portland Chapter

---

**LET ME INTRODUCE THE NEWEST CHAPTER IN A.B.A.T.E. OF OREGON INC,  
THE BLUE MOUNTAIN CHAPTER!!!**



**FRONT; DINK BASS**  
**CENTER;(L-R)-HOWARD BUTS,RICHARD SEXTON,JOYCE COATES,JOHN PESCIA,BEVERLY**  
**EVANS,CRAIG MAYFIELD,ANNETTE ELLIOT,MARCUS MORGAN**  
**AND IN THE BACK ARE BRUCE COATES, AND JIM PHILLIPS**  
**WELCOME TO THE NEWEST CHAPTER,**  
**AND THE BEST OF VICTORIES IN ALL YOUR BATTLES!!**  
**(Who is the kid in the picture??? You did not say.)**

## WHY ADVERTISE IN THE A.B.A.T.E. NEWSLETTER

A.B.A.T.E. of Oregon has over 1,000 members across the State to which newsletters are mailed the first week of every month. In addition, many members have family memberships, which means that the majority of newsletters are read by more than one person.

Our advertising rates are set to allow you the maximum amount of flexibility in purchasing advertising space in our newsletter, and we sell space on a quarterly, half-yearly or yearly basis. Our rates are listed as follows:

BUSINESS CARD	\$25.00	3 months
SIZE:	45.00	6 months
	75.00	12 months
1/4 PAGE:	44.00	3 months
	80.00	6 months
	133.00	12 months
1/2 PAGE:	67.00	3 months
	127.00	6 months
	200.00	12 months
FULL PAGE:	113.00	3 months
	213.00	6 months
	333.00	12 months

To allow even more flexibility, your advertisement may be changed each month for the duration of your purchased time. For example, if you run a business card size ad for three months, you can submit three business cards offering month long or limited time specials. Should you purchase ad space for a year, you could change your ad 12 times!!! Advertising copy **MUST BE SUBMITTED BY THE 15TH OF EACH MONTH** in order to appear the following month in the Newsletter and **MUST BE CAMERA READY**. To order your ad in our widely read newsletter, please submit the following information: Firm's name, address, telephone number, city, ZIP code, size of advertisement, time to run, state whether you want the same ad or a different ad copy each month, and name and title of person placing ad. Send it and your first month's ad copy, prepaid to:

A.B.A.T.E. of Oregon, Inc., P.O. Box 4504, Portland, Oregon 97208  
Please make checks payable to A.B.A.T.E. of Oregon, Inc.

This Newsletter is a publication of A.B.A.T.E. of Oregon, Inc., P.O. Box 4504, Portland, Oregon 97208. All rights reserved. Portions may be reprinted with attribution.

**DEADLINE FOR SUBMISSIONS FOR PUBLICATIONS IS THE 15TH OF THE MONTH PRIOR TO PUBLICATION MONTH.** Submissions will not be returned or saved, unless accompanied by a self addressed stamped envelope. This publication printed by:

Oregon Lithoprint Inc. 611 E. Third St. McMinnville, Or. 97128

## ABATE OF OREGON STATE OFFICERS AS OF JANUARY 1, 1993

<b>COORDINATOR</b> Rich Benson 287-8674	<b>SGT-AT-ARMS NORTH</b> Bear
<b>VICE-COORDINATOR NORTH</b> "Captain Mitch Putman 648-9311	<b>SGT-AT-ARMS SOUTH</b>
<b>VICE-COORDINATOR SOUTH</b> Dennis Deaton 839-4368	<b>NEWSLETTER EDITOR</b> Gordon Hieronimus 253-7343
<b>SECRETARY</b> Deb Fryman 924-0694	<b>PRODUCTS DIRECTOR</b> Angie Jensen 285-4329
<b>TREASURER</b> Joy Hoover 673-1304	<b>PUBLIC RELATIONS DIR.</b> Ken Ray 645-336
<b>MEMBERSHIP SECRETARY</b> Carolyn "Mother" Meerzo 255-7793	<b>RUN COORDINATOR</b> Roger Hendricks 285-4329
<b>LEGISLATIVE DIRECTOR</b> Jim Rhodes 879-2902	<b>HISTORIAN</b> Ronna Buckanon 780-3817
<b>EDUCATION DIRECTOR</b> Mel Yeager 363-1697	<b>WAYS &amp; MEANS DIR.</b> "Horizontal" Frank Way 779-3646
<b>PHONE NUMBERS ABOVE ARE AREA CODE 503</b>	

**Readers should be advised that although A.B.A.T.E. of Oregon supports its advertisers, it does not guarantee the service of those advertisers.**

## TABLE OF CONTENTS

### APPLICATIONS AND INFORMATION

ABATE Chapter Addresses and Contacts	8-11
ABATE Membership Application	39
ABATE Products Order Form	33
BikePAC Application	27
Membership Classified ads	34
MRF Application	28
Road List	NEED TO MAKE A NEW ONE SEND INPUT
State Officers List	2

### REPORTS

Editor's page	3-4
BikePAC Advisory Board Meeting Minutes	5-7
Chapter Reports	8-11
Letter's To The Editor	23-24,26,28,32
State Board Meeting Minutes	6-7
<b>Check out pages</b>	31,32
FROM THE COORDINATOR	35
RUN CAL.	29
A.I.M. Input	24-25

### FLYERS AND EVENTS

Summer Run	38
Cow Chip Boogie W/ Map	36
End of Summer Run	38
SOS	37
AMO Poker Run	36
Fox Creek	37
Beaver Creek RUN	37

### IMPORTANT ARTICLES

Proficient Motorcycling**	12-25
HELMET STOP REPORT FORM	17-18

### EDUCATION

PICTURES	19-22
Membership Chart	16
**Proficient Motorcycling series in this months issue is reprinted with permission by Road Rider's Motorcycle Consumer News. It is a on going series in that mag. I suggest you contact these people and take out a subscription. Call(815) 734-6083 to find out more info about subscriptions.	

# EDITOR'S PAGE

(or there about a page)

So here I go off on a tangent about something that probably only matters to me. The subject of which I am referring to, is that of doing what you said you would do. This subject covers quite a vast range of areas such as the road sign you just past, telling you to slow down, (speed limit, school zone or dangerous curving) or some one saying that they will call you right back, or the ever popular "the check is in the mail". I don't recall how many times I have heard a politician say that they want to "represent my wishes", yeah right! Covered also is the ever popular "I will do that for you right away". This is just as bad as someone saying that they will take on a position in an organization, or committee, and then letting the job go by the way side.

Now for the "MEAT" of my complaint, (I mean editorial). There is an organization that I am proud to say I am a part of (most of the time I am proud anyway). In this organization there are many types of people, professions, lifestyles and "attitudes". I am not sure where some lifestyles stop and attitudes begin and I think that is where my problem begins.

Question: When YOU see a sign posted stating that the road bends left, DO YOU BELIEVE IT???

Question: When YOU see a flier that says: NO ATTITUDES allowed, do YOU leave yours at the gate, home or on the road somewhere, or do YOU bring it with you???

Question: Does any of this make any sense yet???

Let us continue down the list.

Question: When you camp in a group setting, and there is a sign stating LOUD MUSIC and SMALL CHILDREN put up with it or stay away. Do YOU camp near it and complain???

Question: When you have a complaint about an organization you belong to, do YOU speak to the proper people in positions to solve the problem??? Or do YOU stand around a smokey bar and stir stuff up and cause a bigger problem???

Question: Do you take on jobs and not complete them, or screw them up and then quit???

OOOOO0KKKKK enough of this question and no answer period. I guess what I am trying to get across to YOU is that we belong to an organization that needs people to work together, (Cont. next page)



***MA Cycles***  
8202 North Denver - Portland, Oregon - 503-289-4680

Thought you could never afford quality Saddle Bags and Custom gear.  
**THINK AGAIN!**  
**Take 10% off selected First Gear Merchandise in July**  
You'll be surprised. You don't have to look like a magazine.

Seeing is believing so stop in.  
*MA Cycles is located off I-5's Lombard/Interstate Exits. Hours: Tues. - Thurs. 12-7, Friday 12-9, Saturday 10-6*  
*MA Cycles will be closed & heading for the Hills - August 7-16, for Sturgis '94*

get things done that are suppose to get done and talk to the right people about problems. It really does not help our movement to stand around and complain about what YOU do not like. If there is something that YOU do not like, then YOU need to get involved and either suggest a solution or solve it YOURSELF. A.B.A.T.E. OF OREGON, Inc. does need YOUR HELP.

If there is a position in ABATE, that YOU think YOU can do better in than someone else, then by all means STEP UP AND BE COUNTED!!! In the same spirit, if you can not(for some reason or an other)do the job properly but can offer help to some one else, GREAT!!!(To those of you who offer me help, thanks, but I need a rubber room.)

I hear complaints(also compliments) about some aspect of everything, and I tell them to write the editor....HOW MANY DO YOU SEE??? I hear people tell me that they will write and state their view point, and then I hear that they just got jkhfgshlghlgh and let it slip on by. You know people, if you got the "BALLS" to complain, have the decency to complain properly to the proper person(s), for no other reason than the problem might just get solved.

I also see people trying to do things because "no one else will do it". This is WRONG motivation, but I commend the people who step in to do it for that reason only.

Last point I need to make, (and I hope those who I really mean get my point and do the right thing) if YOU do something that you think is right at the moment, and find out that YOU did it wrong. ADMIT your mistake, apologize to those who you have done "WRONG" to, and then go on about your business in the right manor. It takes a BIG MAN to admit when he(or she)was wrong, or what they did was inappropriate. If those people don't fess up to their mistakes or inappropriate actions, then our organization will falter. This is not meant to say anything but swallow your pride and do the right thing, then get back on your

high horse. If YOU don't get off the mighty horse and admit your mistakes then you might as well just ride on out and let someone else take over and get the job done correctly.

To end this page up on a positive note, I think the majority of people involved in A.B.A.T.E. of Oregon, Inc. are doing a marvelous job. I also think that we need to train our leaders of tomorrow, TODAY. Let us get our act together so we all will prosper in the end.

BE SAFE

GORDON W. HIERONIMUS

EDITOR IN CHARGE

P.S. Did I do this right?



**ROAD RASH CYCLE**  
Large Inventory  
**Used Motorcycle Parts**

Hrs. Noon - 5 Mon. - Sat. 3142 SE Malcolm  
(503) 652-5914 Milwaukie, OR 97222



**EASTSIDE MOTORCYCLE**  
SPECIALISTS CO.  
- IN - AMERICAN IRON

3939 N.E. CULLY  
PORTLAND, OR 97213  
503-282-8876

RICKS  
TIMS

**MOTORCYCLE HOTLINE**  
FREE ADVERTISING — NATIONWIDE COVERAGE  
24 Hours a Day • 7 Days a Week • Never a Busy Signal

**1-900-443-5765**  
MOTORCYCLES • PARTS • ACCESSORIES FOR SALE

**1-900-287-4560**  
RIDES • RUNS • TRIPS • EVENTS • COMPETITIONS

To advertise, send a brief description and your name, address, area code and telephone number to:

**MOTORCYCLE HOTLINE™**  
P.O. Box 1391, Graham, WA 98338  
or call 1-206-846-1293 to place your ad. RIDE SAFE!  
Calls are \$1.98 per minute, maximum of 4 minutes. Must be 18.



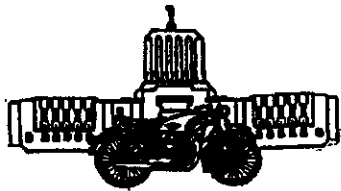

# BikePAC of Oregon

P.O. Box 5612, Salem, OR 97304

Oregon PAC ID # 000019

Jack Fassel 650-9336  
Executive Director

Butch Harbaugh 838-1460  
Legislative Director

Steve Benson 399-7514  
Secretary/Treasurer

## Advisory Board Meeting Minutes-June 5, 1994

Meeting called to order at 12:15 p.m. at Main St. Pizza, West Linn. In attendance: Butch, Nic, Teresa and Sam. Jack excused. Official business could not be conducted because of lack of quorum.

### REPORTS

May's Minutes: Approved as published.

Treasurer's: Not given

Membership: (Written report from Jack) The BikePAC mailing list exceeds 1000 in direct members and interested parties. Thanks sent to John & Pat Molyneux, our newest MABs, OMRA for their generous contribution to the lobbyist fund as well as their group membership, SE Chapter of ABATE for their supporting group membership and Columbia River Chapter of ABATE for signing on as a group MAB.

### Oregon Legislative Report:

Rule Change: Traffic Safety has been contacted in writing concerning the latest language and exception was noted on the phrase "and conforming to this standard" (contained in paragraph 1c in the draft language below) and BikePAC has recommended deletion of that phrase. Ed Margess and Wayne Ivy presented the rule problem to the Governor's Advisory Committee on Motorcycle Safety stating that the rule change is not resolved. Wayne Ivy has scheduled a hearing, in Salem, Monday, July 25, from 4 pm to 8 pm. All interested are invited.

The the following is the last rule language received from ODOT:

DRAFT (4/1/94)

### MOTORCYCLE HELMETS

735-102-020 (1) The [Motor Vehicle Division] Oregon Department of Transportation adapts Federal Motor Vehicle Safety Standard (FMVSS) 218, Motorcycle

Helmets, as found in the Code of Federal Regulations, Title 49, Part 571. [Helmets designed and manufactured to this standard are acceptable protective headgear for operators and passengers of motorcycles, mopeds, and other motor vehicles.]

(a) Adoption of this standard establishes minimum performance requirements for all motorcycle helmets designed for use by operators and passengers of motorcycles, mopeds, and other motor vehicle users when such use is required by law.

(b) The purpose of this standard is to reduce deaths and injuries to operators and passengers of motorcycles, mopeds, and other motor vehicle users resulting from head impacts.

(c) Motorcycle Helmets displaying the manufacturer's DOT symbol and conforming to this standard are deemed legal protective headgear, and therefore comply with ORS 815.050.

(2) For purpose of this rule, a motorcycle helmet is defined as a protective covering for the head consisting of a hard outer shell, padding adjacent to and inside the outer shell, and a chin-strap type retention system. A motorcycle helmet in compliance with this rule constitutes "protective headgear" for purposes of ORS 814.260, 814.269, 814.275, 814.280 and 815.050.

END DRAFT (4/1/94)

Hat's Off Revisited: No report given

May Rally: (written report from Jack) Attendance was 1/3 that of last year's rally. All AMA paperwork has been filed including payment of the insurance bill. Pin sale proceeds at the Rally were \$465. There are still a few pins left for a \$5 donation to the lobbyist fund. Salem Chapter ABATE donated \$40 at the event as well.

Buddy Project: No report given

A.B.A.T.E. of Oregon  
**STATE BOARD MEETING MINUTES**

May 14, 1993

The meeting was called to order by Coordinator Rich Benson in Redmond at 12:15 pm. Chapter roll call indicated that Jackson County, Lane County, South Coast, and Yamhill counties were absent. Therefore we had no quorum. The minutes were read and approved.

**COORDINATOR'S COMMENTS-** Rich reported on the Governors Advisory board meeting he attended. Testimony from Joann Fairchild- seemed biased toward helmet use. It has been suggested that a drunk-rider program be implemented by way of a 1-800 #, and bike trailer. If you are interested ABATE is looking for volunteers.

**CORRESPONDENCE-** City of Fossil Thank-you, Ralph Brockett, S.I.C. Bunch about a M/C Rodeo, Stan Porter TEAM Oregon regarding Eagle Scout (Tom Buchanan) helping M/C Rider that Edd Dahl wrote in June Newsletter, Joy's letter, Oregonian 6/2/94 pro ABATE article, Vera Katz proclamation.

**REPORTS:**

**EDUCATION DIRECTOR-** Mel reported on the O.T.S.E.A. meeting. Also he reported that 168 people have now completed the Instructors Training Course.

**HISTORIAN-**No report .

**LEGISLATION DIRECTOR-**Brian Stoval reported on the MRF Board meeting he recently attended (please see page 4-5 in the June Newsletter) Peter DeFazio needs our support, please volunteer for his upcoming campaign. Peter is a valuable ally for us. Brian asked the ladies of ABATE to contact Elizabeth Furse who supports freedom of choice BUT supports the helmet law! **July 25th is the ODOT Rule Change concerning legal helmets. Be at the Capital hearing RM #A between 4:00-8:00pm. They will accept written testimony and if you would like to testify please coordinate with Bike Pac as their official testimony might be a duplication of yours!** Brian encourages us to all join the MRF , please do so NOW.

**MEMBERSHIP SECRETARY-**Our membership is up 49 and Rich reported a total membership now of 1553. Central Oregon is the fastest growing chapter. Please see the June Newsletter for further info. We did have 100% renewal of expired members last month!

**~~ACTION CYCLE~~**  
***Friendly Unauthorized H-D Service***  
**PARTS ★ LEATHER ★ REPAIR**  
**503-585-6034**  
OPEN 9-6 MON THRU SAT  
**LADIES, LADIES**  
**FRINGE LEATHER**  
**JACKET SPECIAL**  
**\$ 140.00 !!!**  
Salem Oregon



**WE**  
**SHIP**

**NEWSLETTER EDITOR**-Gordon escaped from his kids and reported that all is well with the Newsletter, he needs more pictures, classified ads and verification of Run dates. He also reported that advertisements are up.

**PRODUCTS DIRECTOR**-Angie had Fossil T's for sale and some \$12.00 sweatshirts.

**PUBLIC RELATIONS**- We recognized a Proclamation from Vera Katz, Mayor of Portland, proclaiming May as Motorcycle Safety Awareness Month. Ken also reported our PSA's being shown on Fox 49, and Channel 12. He also had 1" and 3/4" copies available.

**STATE RUN COORDINATOR**-WE STILL HAVE ONE! and Roger deserves all our gratitude, relocating our run and coordinating it all in 3-days or less couldn't have been accomplished by anyone else! THANK YOU ROGER. An extensive report was included in your State Reps packets for each chapter.

**TREASURER**-Our GREAT treasurer submitted her report and rode to the Redwoods! Joy also gets a pat on the back for a good job done. Rich also wanted to thank Douglas County Chapter for their super job at Fossil.

**WAYS AND MEANS**- Frank Way resigned his position. We are accepting volunteers for this position.

**UNFINISHED BUSINESS**-Nic and Captain reported on their trip to Best of the West "the focus of this years conference was on unity, cooperation and working together, ABATE of Arizona and MMA set the tone of the conference by demonstrating what working together is all about" see report on page 34 of June's Newsletter.

**NEW BUSINESS**-The Blue Mountain chapter was given its charter. John Coates Coordinator and Marcus Morgan is their State Rep. Welcome Blue Mountain to ABATE of Oregon Inc. Other New business included the speaker phone idea for winter months to connect Eastern Oregon reps to Eugene for State Board Meetings.

**Announcements**:Teresa explained Bike Pac to some new members, as a political action organization, their current project is the Voters Pamphlet for November elections. Bike Pac is sanctioned by the AMA and is the only political action organization they do sanction. A donation of \$50.00 per year IS DEDUCTIBLE and they NEED YOUR SUPPORT. Thank-You. Nic motioned to adjourn the meeting at 2:55 pm and we did. Minutes submitted by Deb Fryman.

## *Your Motorcycle Accident Lawyer*

# **SAM HOCHBERG**

**Attorney at Law**

*Dedicated to Serving Those Who Ride*

- FREE CONSULTATION
- NO RECOVERY = NO FEE
- EXPERIENCED LAWYER & MOTORCYCLIST
- MY GOAL - YOUR PROMPT CASH SETTLEMENT
- ALSO AUTO, TRUCK AND OTHER INJURY ACCIDENTS



*Member of ABATE of Oregon  
Legal Counsel for BikePAC of Oregon  
Authorized Oregon Representative for the Law Offices of Richard M. Lester*

**DOWNTOWN PORTLAND OFFICES SERVING YOU STATEWIDE**

**24 Hours - Toll Free 1-800-531-2424**

## CHAPTER REPORTS

### Blue Mountain

Meets 1st and 3rd Sundays, 3:00 pm  
Klondike Pizza, 828 Southgate, Pendleton  
Chapter Address: 1306 S.E. Court, Pendleton, Or. 97801  
Chapter Contact:

Hello from the NEW chapter in NE Oregon! This is our first report and I have to say all of us feel enthusiastic. We hope to be not just successful but very successful. We have a real good selection of officers. Everyone is looking forward to fun and HARD work to support our rights as motorcyclists. We could not have formed this new chapter had it not been for the efforts of Rich Benson - Coordinator, Craig Mayfield of Paramount Cycle, and all those who showed up to the meetings or were otherwise involved. Thanks!

On June 11th our chapter state representative - Marcus went to the state board meeting in Redmond, as did our coordinator Bruce and myself. We received our charter and it was a good meeting, sort of! Not enough chapters showed up to make a quorum. So no business could be voted on. We were disappointed, to say the least, in those who didn't show. It was their loss. We had good weather, beautiful scenery, a great barbeque, and a lot of good people to visit with. Our thanks to the Central Oregon Chapter for their hospitality. And a special thanks to Mitch and Cindy (Coordinator/Secretary) for putting us up for the night.

United We Stand - NO Quorum We Fall !!!!!!!!!!!!!!!

J-P

Take Care and Ride Free.

### COLUMBIA RIVER

Meets 2nd & 4th Sundays, 12:30 pm  
Cactus Club & Diner, 8131 N. Denver, Portland  
Chapter Address: P.O. Box 11817, Portland, OR 97211  
Chapter Contact: Angle, (503)285-4329

Hello out there:

Coming from Columbia River Chapter we are in full swing for the Run to the Sun. Hope to see all of you there.

At this time I would like to direct the attention to the couple who volunteered to go to the State Board meeting for us. I apologize for the bad conduct given you by a certain ex-member of ours. I personally was totally embarrassed when it was brought to our attention. Please don't let one sour apple chase you away. There are a lot of us who do care, and appreciate all the help we can get.

50/50 won by Kevin, he donated movies back to chapter, way to go Kevin. Craig Bowley lost on Membership drive, where are you? Who are you?

Come to a meeting find out the facts until next time,  
RIDE SAFE.

Lana

(208) 695-6631

All current HOG or ABATE  
members 10% discount

**Columbia Motorcycle**  
HARLEY DAVIDSON



JAMES T. KREOFISKY  
Owner

331 E. 4TH PLAIN BLVD.  
VANCOUVER, WA  
SINCE 1945

"No tax to Oregon buyers"

### CENTRAL OREGON

Meets 3rd Wednesday, 7:00 pm  
The American Legion Hall, 8th Street, Redmond  
Chapter Address: None at moment.  
Chapter Contact: Cindy Maxwell (503)382-7079

YIPPIE KI YO KI YA From Central Oregon!

The reason for the greeting is that it is RODEO weekend here in Sisters, a time that we generally try to avoid.

WOW!! Great time had at Fossil. Can't wait until next year. I think that everyone that came from our chapter (GOOD TURN OUT) and most of everyone else was definitely FOSSILIZED, at least I felt that way Tuesday morning when I had to get up and go to work.

Well, we had a few changes happen this last month. Terry "Bull" Thompson resigned from his position as our Coordinator because of some happenings in his personal life. At the same time Scotty Kingsberry our Sgt. at Arms also resigned his position. A new Coordinator and Sgt. at Arms were elected at the meeting, Mitch "Mad Max" Maxwell is the new Coordinator, and Andy Duran accepted the Sgt. at Arms position. Thanks to all the members of this chapter for standing with Bull in his decision, and excepting the changes that we are going through so soon in our development.

Tom Kent just passed some exciting news to me about how the membership is growing, 88!!!! members, Yea, lets keep those new people coming in, and the good information that we have to share going out. Hope to see all 88 of you at our next meetings. It would be nice to have your voice, vote, and smiling faces there when issues are brought up for vote. Come and have a voice in determining the future and direction of YOUR chapter. Your vote counts!!!!

Catch ya next month,  
Cindylou Who,  
the NON buckaroo

### DOUGLAS COUNTY

Meets 3rd Sunday at 11:00 am  
Round Table Pizza, Roseburg Valley Mall, Roseburg  
(Contact Ed Halkyard at (503)673-6120 for info.)  
Chapter Address: P.O. Box 61, Roseburg, OR 97457  
Chapter Contact: Joy Hoover(503)673-1304

Hi everybody,

Well D.C. ABATE survived another Fossil gate experience. We identified a little known disease. We named it Fossil Gate Syndrome. I want to thank all the D.C. ABATE crew for all your help. Also all the other folks who helped us at the gate. Thanks also goes out to Rich, Roger, Angie, Bear and all the security and info booth people who helped us over the weekend. I should also apologize to everybody I growled at over the weekend I did occasionally get short fused. Me, Tommy, Kim and Sally stayed and partied till the cows came home literally, about 400 head came through on a drive about 8:00 tuesday morning. They didn't stomp our gate stand flat but we managed to lose it anyway. Kim's bike broke on the way home so Tommy unloaded it near Wikklup Junction to haul the bike home. When we went back to get it some low lifers had taken it. So it goes sometimes. So we built a new improved version last weekend. One quick political note hot on the heels of the assault weapon joke we now have Brady 2, if this

becomes law it will make instant felons out of most of us. They can't prove any of this will do anybody any good but if Brady 2 passes it will only take the jerks a week before a more restrictive bill will be introduced, so if you want your freedom stand up and be counted till next month.

Ride free.  
Chris Vieira

**(THE FOLLOWING HAS BEEN EDITED BY THE STATE NEWSLETTER STAFF TO REDUCE DUPLICATIONS AND TO SAVE SPACE.)**

ABATE of Douglas County 5/15/94 Chapter minutes. Correspondences are being kept in a three ring binder for all to read.

Reading of minutes from the last meeting is no longer in our procedures.

Treasurers report states ending balance of \$517.29.

Membership up 3 for a total of 144.

Legislative report states that thanks are in order to Rep. Peter DeFazio for his support on H.R. 799. We need to get a network going to make sure that Town Hall meetings are attended with our view point, meet the candidates and give your input for them to consider.

Education report included a thank you from Mel Yeager to the D.C. Chapter for thier support.

Now about that motion that the D.C. Chapter Reps made at the State Board meeting, it was not amended for the Board to vote on again nor was it meant to cause any undo stress or arguements. We Apologize for any(if any) of the aboved mentioned side affects.

We had a speaker appear, Joe Stewart, who spoke on gun issues. Chris has any details if you want to contact him, or call Joe at (503) 672-5540 or write to him at 1376 N.W. Whipple St., Roseburg, Or. 97470.

Camp Easterseals was a blast for all, and a lot was accomplished. Thanks to all who particapated. A side note about sending Ronnie Stuebert last year, we turned it in too late. Kimmy suggested passing the hat and we collected \$84.00, also Cindy suggested that the 50/50 drawing go to this cause. Total of \$95.00 at the last meeting was collected. A jar was at the Fossil gate, and Cindy donated proceeds from her earnings on her T-shirts. Ya Members!!

Regional Run(S.O.S.) We were asked to do the Bike Show, and it is not confirmed we will do it yet. The lift raffle goes on, contact Kim(503)498-2412 for more info. South Coast will do the gate and security. So far preparations are smooth.

**Stump Lake Campout has a new date make a note that it is now August 27th and 28th.**

New Business: Officers meetings will be at Tom and Sally Woodall's house, contact Ruth Clark for directions(503)459-3855(THANKS MOM AND DAD VERY MUCH).

Legions of America...Our chapter is declining any involvement with this event at this time.

50/50 drawing won by Joy Hoover=\$11.00

Meeting adjourned at 1:25pm

Submitted by The RAW RAC

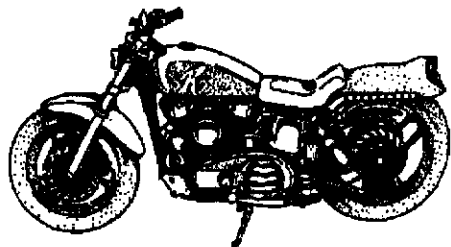

## **JACKSON COUNTY**

**Meets 1st & 3rd Sundays, 11 am**

**Oreaganos Pizza 828 2nd Ave., Gold Hill**

**Chapter Address: P.O. Box 1184, Medford, OR 97501**

**Chapter Contact: Gene Nelson (503)855-7345**

We have tied up a few more loose ends concerning S.O.S. I have received excellent response from Douglas and South Coast chapters. It has been difficult to get started with the regional run idea. But if everybody follows through with their commitments things will go well.

We still have raffle tickets available for the motorcycle lift. Only 1000 have been printed. You do not need to be present to win. We will have the drawing Saturday evening during S.O.S. The price of tickets are 3 for \$5.00. Contact me by mail at: Gene Nelson, PO Box 82, Gold Hill, Oregon 97525.

This is an excellent lift with a retail value of \$500.00. You can't win if you don't play.

I still need a water truck for S.O.S. It is requirement for our permit. No water truck - no S.O.S. Please get a hold of me if you can help. Fire danger will be high this year, please help.

TCB

Gene Nelson

## **LINCOLN COUNTY**

**Meets 1st & 3rd Fridays, 7:30 pm**

**Moby Dick's Restaurant, Newport**

**Chapter Address: P.O. Box 665, Newport, OR 97365**

**Chapter Contact: Vicki Lechner, (503)563-3520**

Well here is the Lincoln County Chapter report coming from high in the hills of the coastal mountain range, late, and typed on this wrinkled piece of Dustys' left-over notebook paper from 8th grade. (We're on Summer vacation now).

I lost the original Chapter report... somewhere! BUT our chapter is fortunately doing better than I. We have now completed our first Highway clean-up and discovered that the citizens littering the most are filter-cigarette smokers. After the clean-up we gathered at Gary & Vicki Lechners for a pot-luck barbeque and enjoyed a good afternoon together.

We are completing the arrangements and orders for our Beaver Creek Run already. The band had been secured, beer ordered and Gary has been busy with his new lawn mower making numerous trips across the field. (Gee that guy loves to ride!) Anyway, the Run is coming together real well. By the way this year its August 13th and 14th. Yea, we know its over Sturgis... but for those of you that can't afford to make the big.. Run take a look at our flyer.. or just head over to the coast and join us for a great week-end in August.

We had a successful trip to Fossil. As a chapter we had a nice ride in sunny weather both ways, nobody broke down permanently... and no-one puked in their tent... trophies/ribbons were had by Randy Becker, Gary Lechner, and myself. We were sorry to hear that someone left fires...burning... bad judgement and that Commander Cody played so late Sunday, but we realize that NO Run comes off perfectly and also believe Roger deserves a great pat on the back for, in 3-days obtaining another Run site, and over-came disasterous odds to pull-off the party. We, at the coast THANK YOU ROGER...

So for now...

ride safe and sober...

deb



### **NORTH COAST**

Meets 1st & 3rd Wednesday, 7:00pm  
Pizza Harbor, Seaside  
Chapter Address: P.O. Box 468, Seaside, Or 97138  
Chapter Contact: Don Smack, (503)738-7156

NO REPORT, FIRST TIME.

### **N.E. PORTLAND**

Meets 1st & 3rd Wednesday, 7:30 pm  
Izzy's Pizza, 1307 N.E. 102nd, Portland  
Chapter Address: P.O. Box 5792, Portland, OR 97228  
Chapter Contact: Rusty Taylor (503) 777-5121

Fossil was great. I had one of the best times this year. Last year I was working the grave yard shift, so when Fossil came around I hadn't made the transition to being awake during the day, so I slept most of the time and missed the night action. This year Friday and Saturday I caught the bug going around, but I managed to squeeze in some good times between my trips to the woods to pray. Anyone have some videotape or pictures I might like to see???

I shook the bug on Sunday and was able to stand up all night and party with the rest of the hard cores. Wasn't Commander Cody great? And the titty contest? Anyone have some videotape or pictures I might like to see???

Well on to business. We have a new Legislative Director, Cindy, She's doing good so far. Randy is our new Public Relations Officer. There are people out there who can be coerced in to office,(oops)! mean elected in to office and volunteer some of their time. It doesn't take a lot of an individuals time to fight for your personal rights when there are lots of people taking a little time here and there to help out. Well got to go.

See ya,  
Road Rash



## **INTERSTATE TAVERN**

- \* CRAB & SHRIMP COCKTAILS
- \* SANDWICHES
- \* PIZZA TO GO
- \* OPEN 7 DAYS A WEEK

JUILENE WUOLLET  
PROPRIETOR

119 B STREET  
HWY 30, RAINIER, OREGON  
503-556-9950

### **SALEM**

Meets 2nd & 4th Mondays, 7:00 pm  
Pietro's Pizza, 1637 Hawthorne Ave NE  
(Call 581-3138 or 581-8637 for Information)  
Chapter Address: P.O. Box 13957, Salem, OR 97309  
Chapter Contact: Nic Oliver (503)394-3456

Greetings & Salutations:

We are excited to inform you that our Fox Creek Run will be held as in years past, the first week-end in August. Due to an overwhelming interest and increased participation from our members, we are planning another spectacular Fox Creek Run. The chapter is pulling together stronger than in the past few months and we are looking forward to seeing everyone there.

At our next meeting we will be taking nominations for coordinator. Due to family obligations, Nic has resigned as coordinator.

Remember, Fox Creek, same time, same place.  
Have a great summer, Ride safe.

Ruby

### **SOUTH COAST**

Meets 3rd Sunday, 11 am  
Gino's Pizza, 1324 Virginia Street, North Bend  
Chapter Address: P.O. Box 222, Lakeside, OR 97449  
Chapter Contact: Tony & Vikki Haines, 759-4961

NO REPORT, SECOND TIME.

### **S.E. PORTLAND**

Meets 1st & 3rd Sundays, 12 Noon  
The Pizza Baron, S.E. 122nd & Division, Portland  
Chapter Address: P.O. Box 90233, Portland, OR 97290  
Chapter Contact: Larry Schalk 774-2479

Hello;

I hope you all survived Fossil, and are doing fine. Wasn't Fossil great? The weather wasn't wonderful, but at least it wasn't pouring. The weddings were great, and congratulations to all three couples that got married there.

We now have a set location for the Summer Run, it will in Brightwood.

I hope you all are trying to sell all 2940 tickets for the Harley. You know if we do sell them all, we can get another Harley to raffle off, and just think of all the money we will raise for Shiners Hospital.

In July our Chapter will have only one meeting, it will be July 17th. At the same place, Pizza Baron, 122nd. & Division, same time, 12:00, noon.

HAPPY TRAILS,  
DEBBY

- TIRES
- BATTERIES
- TUNE-UP
- BRAKES
- AIR CONDITIONING
- SHOCKS
- CAR SERVICING
- RADIATOR
- EXHAUST
- SUSPENSION
- ELECTRICAL

**ARCO**

**JIM TAYLOR'S ARCO**

5710 N.E. FREMONT  
PORTLAND, OR 97213

- SINCE 1981
- CERTIFIED MECHANICS

**284-6594**

**WASHINGTON COUNTY**

Meets 2nd & 4th Tuesdays, 8:00 pm

Round Table Pizza, 2473 N.W. 185th, Beaverton

Chapter Address: P.O. Box 830, Cornelius, OR 97113

Chapter Contact: Don Murry 648-9651,

Dave at V-Twin (503)648-4103

Hello from Washington County:

Well summer is upon us, and except for a few days of needed rain, the spring was good for all of us who were up on two wheels and able to enjoy the warm days and cool nights. Fossil was as good as it could be amongst all the confusion. Our hats are off, (literally), to all of you who put forth the effort to bring this week end adventure together. Special thanks go to the "Blue Sky" Restaurant and the great grub that Darrell and Ronna fixed for everybody.

The Tri-County End of Summer Run will be September 23 to 25, at Horning's Hideout, in North Plains. Fliers are out, with maps included on the flier. Tickets are also available, just contact any of the three chapters for info.

We had a poor turn out at Cruisin' Sherwood, with only 5 scooters entered, 3 that were ABATE members. The person who won the MC class, was not a member and couldn't be enlisted at this time. We generated a lot of interest from everybody there, and passed out fliers and literature. We were also invited to enter the Burns Bros., Cruise In, August 27. (10:00 to 4:00, \$8.00 per entrant) and the Molalla, Cruis'in, July 4. (2:00 to 7:00, \$5.00 per entrant)

Looks like our home is going to stay at Round Table Pizza, in the Tannasbourne Village, (behind Pier 1 imports), Sunset Hwy and 185th Street. So far we have had plenty of scooter parking spaces right in front of the restaurant and on the sidewalk. We've got the meeting length down to about 90 minutes now, which has helped attitudes a little. The attendance drawing is still growing, you've got to be there to win.

Well that's about all we've got for now. See ya at the runs.  
Linda

**YAMHILL COUNTY**

Meets 2nd Sunday, 3:00 pm

Westward Ho, McMinnville (3rd Street)

Chapter Address: P.O. Box 1179, McMinnville, OR 97128

Chapter Contact: Kraig, (503)876-5135

(THE FOLLOWING HAS BEEN EDITED BY THE STATE NEWSLETTER STAFF TO REDUCE DUPLICATIONS AND TO SAVE SPACE.)

YAMHILL COUNTY CHAPTER MINUTES JUNE 11, 1994

guests: Long Shot, Don Stephenson

9 people signed in.

Minutes were approved from last meeting

Treasurer reports Checking\$153.25,Savings\$376.45,Rider

Education Reimbursement Fund\$120.00

Membership is now at 27

We need a Ways and Means Officer

Officer election results:

- |                  |                |
|------------------|----------------|
| Coordinator      | Kraig Markusen |
| Vice Coordinator | Donna Rhodes   |
| Secretary        | Steve Roberts  |
| Treasurer        | Donna Rhodes   |
| Membership       | Sandy Sharrar  |

- |                |                 |
|----------------|-----------------|
| Historian      | Sandy Sharrar   |
| State Rep.     | Jim Rhodes      |
| Sgt. At Arms   | James Dunnwoody |
| Ways and Means | NEED ONE        |

Thanks to all remaining officers and to the new ones welcome aboard. We need ideas on how to raise needed funds to do the End of Summer Run. If YOU have any come to the next meeting and share.

Next meeting is July 10, 1994 PLEASE ATTEND.

In closing I would like to take this time to thank all Yamhill Co. members and friends for all thier help. As you can see I did not run for office this past election. It is my sincere hope that Yamhill grow strong and prosper over the next year. Again thanks and continued success in what ever you do in the future. I hope you take good care of your new secretary, Steve Roberts.

Don Stephenson

**RIVER ROAD HOUSE  
TAVERN**

**RIVER ROAD & McLOUGHLIN  
MILWAUKIE, OREGON**

**GOOD FOOD**

**THE PLACE WHERE  
FRIENDS MEET**

**ABATE MEMBER - SUPPORTER**

**OWNER: SHIRLEY FEARSON**

**SPENCER M. NEAL**  
ATTORNEY AT LAW

**GINSBURG, NEAL & LESAGE**

500 Yamhill Plaza Bldg.  
815 S.W. Second Ave.  
Portland, OR 97204

(503) 221-1792  
Fax (503) 223-1516

# Taking the High Road

Article and Illustrations  
by David L. Hough

**B**iker Bill is heading for the California Coast, two-up and loaded for a two-week trip. The road twists around sharp switchbacks between short straights as it climbs through the coastal range. For several miles Bill has tried to pass a creeper car towing a swaying travel trailer that brakes to a crawl for the corners, but the driver puts the pedal to the metal in the straights just where it would be safe to pass, and Bill prefers not to take any unnecessary risks. He also senses that the driver is aggressive towards motorcyclists.

Finally, Bill spots a left-hander ahead where he can see all the way around the corner and back up the ravine. As the brake lights come on, Bill leans over hard, gasses it and cruises around. Sure enough, the driver immediately romps on the pedal to chase the motorcycle up the grade. So Bill holds the throttle on perhaps a little more than he normally would, and delays braking a little later to gain some distance. He feels his wife's hands tensing up on his waist as he brakes hard just before the uphill right-hand switchback. Bill takes a quick glance in his mirror to confirm adequate distance ahead of the aggressive driver, then gets off the brakes and leans over sharply into a nice, delayed-apex line towards the steep uphill switchback.

But just as Bill twists his head around to look through the corner, a loaded logging truck announces its presence with a loud *blat* of the compression brake and Bill realizes three things: (1)The truck will be in the turn while he is still in it, (2)the trucker can't brake any harder, and (3)the truck's trailer wheels will cross the centerline by several feet. Bill pushes hard on the right grip to make a quick mid-turn correction. The machine responds

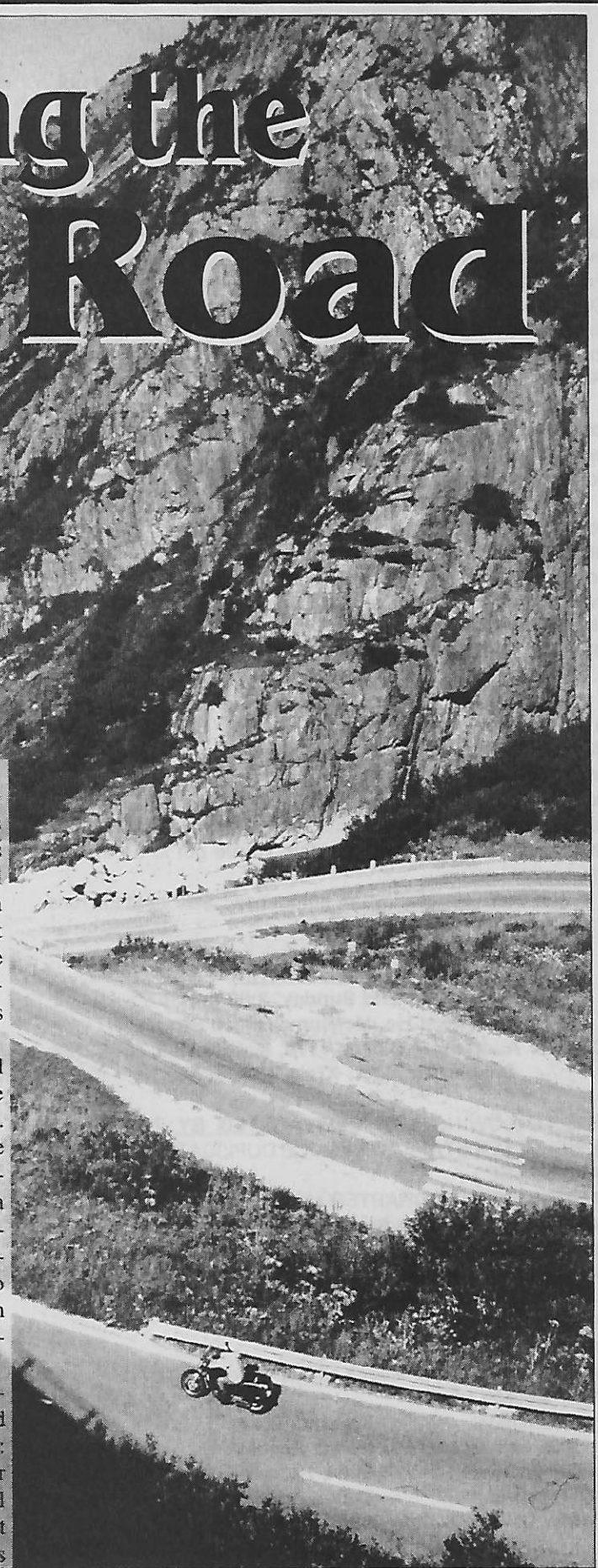

by leaning over to the limits of traction and ground clearance, front tire howling and something beneath the footpegs making a trail of serious sparks. The trailer is so far over the line that Bill's helmet almost grazes the underside of the logs between truck and trailer, but the bike manages to claw its way toward the inside just quick enough to miss the trailer wheels. Later, Bill realizes that his habit of "push steering" saved them from a crushing death, and that a near-miss looks just like a crash until it doesn't happen.

We've filled up a respectable number of pages on cornering, but usually with the assumption that the corners are more-or-less on the level. In the real world, corners are often combined with hills, and if the road is climbing or descending at steep gradients, we've got to compensate to keep from running out of road.

So, this month, let's consider the implications of cornering and braking while negotiating steep grades, both up and down. There are several important considerations, including traction, gravity, inertia, and spacial orientation. Let's first review some of the physics, and then see if we can offer some tips for maintaining directional control while also staying out from under the wheels of other vehicles.

## Inertia and Gravity

When we corner on a two-wheeler, we balance the forward inertia of the machine against gravity with steering input, to maintain the desired angle of lean and therefore direction. Whether turning, accelerating or braking, we depend upon gravity to load the tires and maintain traction. And we also must manage the effects of inertia, which "transfers weight" to the rear wheel during acceleration, and to the front wheel during heavy braking. So long as everything is on the level, inertia may change the loading on the tires as we speed up or slow down, and the force of gravity remains essentially neutral. But with the road surface pointing upwards or downwards, gravity also changes the tire loading, and therefore available traction.

## Uphill

With the front end pointed uphill, gravity is pulling more towards the rear wheel. Remember that traction is limited to

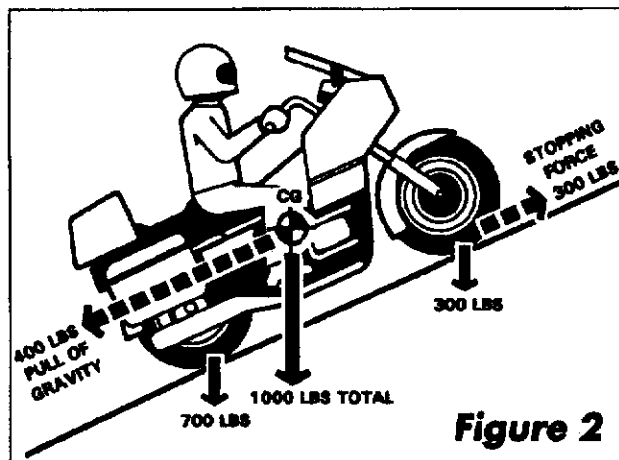

**Figure 2**

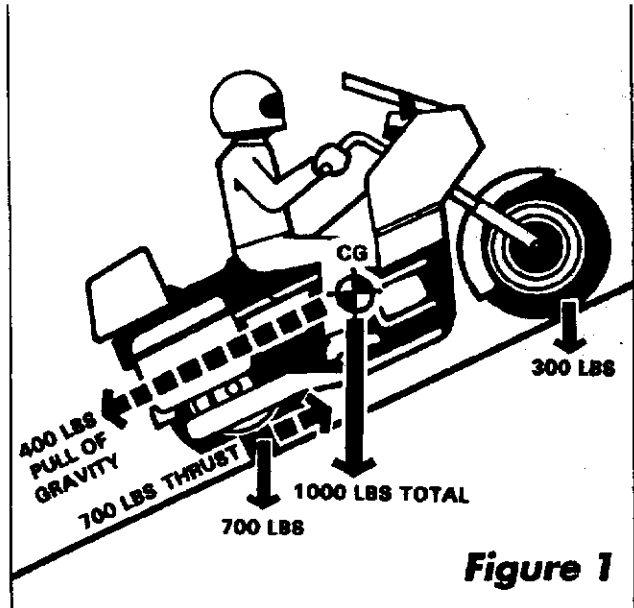

**Figure 1**

how much force is pushing the tire into the road surface. For acceleration, going uphill is good news from the standpoint of traction. Both gravity and inertia load the rear tire, and it will have maximum traction to thrust the motorcycle forward. With a total weight of say, 1000 pounds, there might be 700 pounds on the rear tire and 300 pounds on the front tire. So we could theoretically use 700 pounds of engine thrust to push the bike uphill. Although gravity is pulling on all parts of the machine and rider, let's imagine that gravity is pulling on the center of that mass, or "center of gravity." With a downward pull of gravity of 1000 pounds, there might be something like 400 pounds of force pulling the motorcycle backwards down a steep hill. (Figure 1)

Uphill, all that weight transfer to the rear end unloads the front tire, so there is less traction available for balancing and steering. If the machine is already heavily loaded on the rear with baggage or a passenger, even a modest increase in engine thrust can lift the front tire off the ground. And, with the front tire wagging in the air, steering the front wheel won't have much effect on directional control. Even if the front tire remains in contact with the road, the reduced traction means it can't provide much force to make the motorcycle turn. The front tire may howl or drift sideways, and the bike could slip across the centerline or off to the shoulder.

Stopping while going uphill is easy, because gravity is already pulling backward on the bike, and this backward pull of gravity helps counteract the forward inertia of the machine. That's why rolling off the throttle has such an immediate effect, and why we don't need much braking to make a quick stop. The problem with braking while heading uphill isn't getting the bike stopped, it's holding the motorcycle from sliding backwards downhill. With most of the weight perched on the rear wheel, the reduced traction on the front tire may not provide enough stopping force. In the same situation, the downhill pull of gravity is greater than the maximum front wheel stopping force. (Figure 2)

More than one sweaty-palmed rider has dabbed furiously for balance while sliding backwards downhill with the front brake locked full on.

## Downhill

The reason why accelerating downhill is so effortless is that gravity is already pulling the machine downhill. Of course, there is less traction available at the rear tire, but we don't need much traction to accelerate. Gravity might be pulling downhill with a force of 400 pounds, added to the engine's potential thrust of 400 pounds. (Figure 3) The machine isn't likely to wheelie even if loaded heavily at the rear, because gravity is pulling more toward the front wheel.

Stopping while traveling downhill is another matter, because the brakes have to overcome some of the gravitational pull plus the inertia of the speeding machine and load. Given the same angle of slope, the downhill gravitational pull is constant at any speed, but the inertial force increases or decreases as a function of speed. What's significant is that the inertial force increases more rapidly than speed. Very roughly speaking, inertial forces more than *double* with an increase in speed from 50 to 70 mph. That's the reason for those "TRUCKS USE LOWER GEAR" signs and "RUNAWAY TRUCK" lanes. If the speed of a heavy vehicle is allowed to increase, inertia can quickly increase to the point where inertia plus the downhill pull of gravity is stronger than the brakes or available traction. Today's motorcycles, with their much lighter weight and powerful discs, will seldom fail to brake the wheels to a stop, but there is a limit to tire traction.

---

... inertial forces more than *double* with an increase in speed from 50 to 70 mph.

---

The steeper the downgrade, or the slipperier the surface, the greater the problem. If the grade is steep enough, or the surface slippery enough, it is easily possible to reach a speed where the machine can't be slowed whether on the tires or on its side. (Figure 4)

While most of us would recognize that we are approaching the

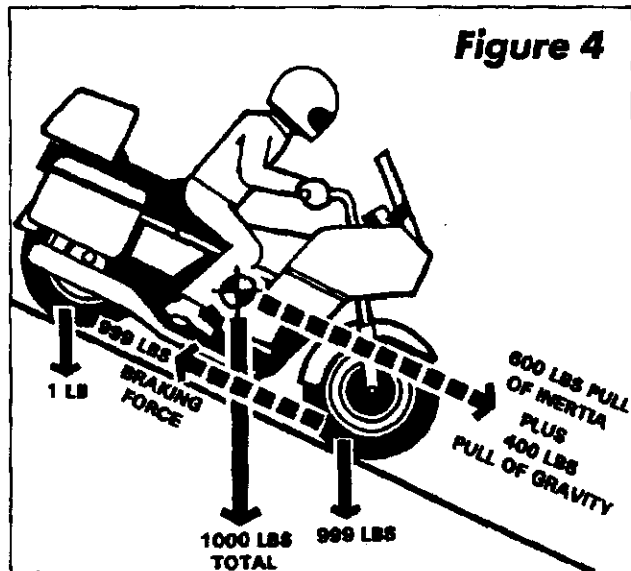

Figure 4

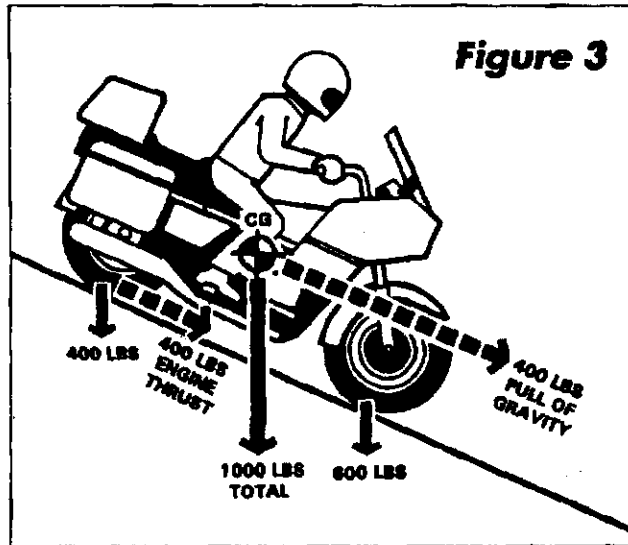

Figure 3

limits during a fast downhill run on wet pavement, we may underestimate the implications of inertia and simply run out of road. For example, we might easily be able to slow to cornering speed from 40 or 50; but from 60 or 70 we could eat up so much more braking distance that we arrive at the corner before we can decelerate to cornering speed. This may help explain why so many single-vehicle motorcycle accidents occur at downhill turns.

## Tactics on Hills

With the physical dynamics in mind, let's review some of the tactics veterans use to maintain control on steep hills.

### Starting and Stopping

Veterans have learned some fancy footwork to hold their roadburners in position on steep hills. The correct technique is to hold the motorcycle with the rear brake, keeping the bike in gear but the clutch disengaged. That allows the left foot to support the machine. If the bike isn't already in low gear, be prepared for a little tap dance to shift weight back and forth quickly and get it in gear before the machine slides backward downhill. Depending upon machine and load, it may require some clutch abuse to get rolling uphill. Many of today's motorcycles have high horsepower at high revs, but very little torque at low engine speed. On such machines, it is necessary to rev the motor and slip the clutch, and it takes a delicate clutch hand to keep from doing a wheelie as the engine suddenly climbs the torque curve. If you really have trouble getting started on a very steep hill, remember the old bicycle trick of starting by angling across the lane rather than straight uphill.

### Uphill corners

When negotiating steep uphill turns, remember that the weight shift to the rear has unloaded the front tire and reduced traction needed for balancing and steering. It is important to separate any strong acceleration from dramatic steering input. There is a tendency to slow down too much because of the tight turn, but grav-



ity will quickly overcome inertia. Use the inertia of the machine to carry it uphill, just to the tightest part of the corner. Assuming you can use all of your lane, stay well toward the outside of the curve and get the machine turned while inertia is still pushing it uphill, then get the bike upright and accelerate in the straightest possible line. (Figure 5)

On uphill corners, the steepest part of the slope will be toward the inside of the curve. On right-handers, move closer to the centerline. On left-handers, the right lane will have a less dramatic climb at the switchback, but stay to the outside anyway to avoid leaning over into oncoming vehicles. It may be helpful to imagine the relative forces of inertia and gravity and to predict the point where forward inertia will balance against the downhill pull of gravity. That's the point where sharp steering input should be over, and engine power needs to come on. If you find that you must get on the throttle while still making the tight part of the turn, try approaching such uphill turns a little faster.

Stopping on steep downhill grades can require considerable force on the front brake. Less braking is available on the rear because of the weight shift to the front, so wise riders use the rear brake very cautiously to avoid a slide-out (and the possibility of a resulting highside crash.) Remember, that shifting down and popping the clutch can slide the rear tire loose, just as if you had jammed on the rear brake. Blip the throttle enough to get engine speed up to where it needs to be for the lower gear. And, if you are already on the rear brake, release the rear brake as you shift. Inertia and gravity are also pulling on our body, which we resist by hand pressure on the grips. We should be prepared for both the "handstand" feeling on our palms, plus the "rubbery" feeling from the front tire being so heavily loaded. The handstand feeling is more pronounced with machines having rearward-positioned footpegs and forward-positioned handlebars.

When descending a steep hill, there ought to be plenty of traction for balancing and steering, because of the weight transfer to the front tire. But, if we are already braking to keep speed from increasing, we are using up traction which would otherwise be available for forcing the front tire into a curve. We can't expect the front tire to have such unlimited traction that we can be hard on the brake and also leaned way over. It's a sort of Catch-22. If we brake harder to decelerate, we can't corner as sharply. If we get off the brake to corner sharply, the machine will accelerate, and the increased inertia will demand more traction to turn.

Descending steep switchbacks, it is often necessary to stay on

the brakes even while turning, to control inertia. So smart downhill riders brake harder during the straight line approach to a curve to scrub off the big-time inertia early. Then they can ease up on the front brake to allow most of the traction for cornering, then allow speed (and inertia) to increase during the next straight.

## Spacial Orientation

When the road is making dramatic ascents or descents hanging on the side of sheer cliffs, it is easy for a motorcyclist to get a little disoriented or perhaps a bit nervous. Many riders find it helpful to keep their eyes level with the horizon even while leaned over on steep corners.

It is very normal, for our imaginations can get carried away with scenes of falling downhill or sliding off the edge of the abyss, but some of us are bothered more than normal by acrophobia (fear of heights). Remember our lessons about target fixation: Look where you want to go, not over the edge, especially while moving. If you want to appreciate the view, stop near the uphill side of a left-hand switchback, farther from the edge, and where there is often a nice comforting rock wall to lean into.

Now, consider Biker Bill and his near-miss on that steep switchback. How did he manage to avoid getting crushed beneath the wheels of that log trailer halfway across the centerline? Was it Proficiency—or Luck?

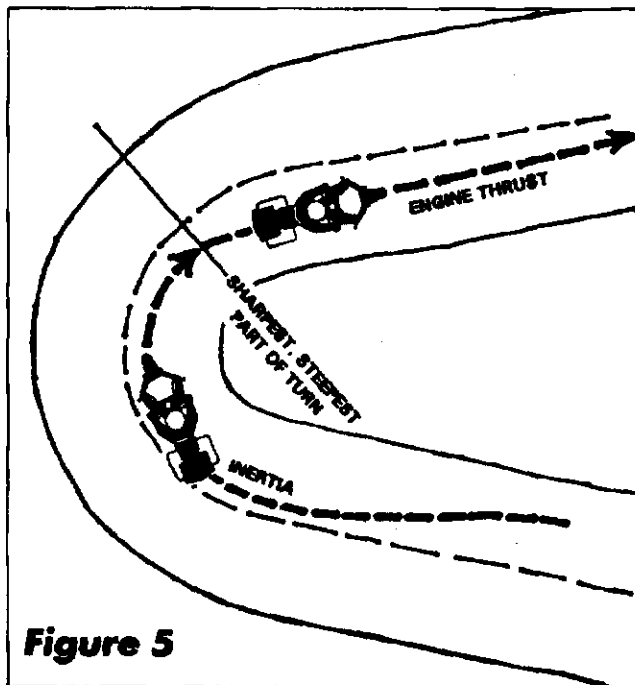

Figure 5

### Three tactics that helped:

- ◆ First, Bill looks where he is going. Sure, he got surprised by the sudden appearance of the logging truck, but he *did* see it in time to take evasive action, and he *did* look to the road ahead, not under the tires.
- ◆ Second, he always practices accurate steering control by countersteering or "push steering." He is capable of making the machine go to the limits if needed, and in an emergency he does that without having to think about it.
- ◆ Third, Bill always rides within his envelope. Even though pushed faster than he would have preferred into a blind uphill corner, he still had enough traction in the bank to make a crucial mid-corner correction.

We should all be so proficient.

	TOTAL	GAIN/LOS	EXP/TRANS	NEW/RENEW	TOTAL
CHAPTER	6/1/94	6/1/94	6/1/94	6/1/94	5/1/94
BLUE MOUNTAIN	no	numbers	to	use	yet
CENTRAL OREGON	88	18	0	18	70
COLUMBIA RIVER	109	11	2	13	98
DOUGLAS COUNTY	153	9	2	11	144
INDIAN CREEK	224	35	8	43	189
JACKSON COUNTY	87	-7	11	4	94
LANE COUNTY	NOT47	A-5	CHAPTER6	ANY1	MORE152
LINCOLN COUNTY	93	-3	3	0	96
NE PORTLAND	188	-5	6	1	193
NORTH COAST	40	0	7	7	40
SALEM	95	-9	15	6	104
SE PORTLAND	219	11	12	23	208
SOUTH COAST	65	-2	3	1	67
WASHINGTON COUNTY	118	3	1	4	115
YAMHILL COUNTY	27	-7	7	0	34
TOTAL	1,553	49	83	132	1,504

**ACCIDENT??**

ABATE OF OREGON ENDORSES  
THIS PROGRAM FOR ITS MEMBERS

**RIDE FREE  
RIDE  
PROTECTED**



Local Oregon Offices  
To Serve You

Law Offices of  
**Richard M. Lester**  
A Law Corporation

- Free Legal Consultation
- Founder of **Aid to Injured Motorcyclists**
- Bikers Helping Bikers
- No Recovery = No Fee
- We Make House Calls
- Financial Sponsor of  
**National Coalition of Motorcyclists**

24 Hours — Toll Free

**(800) ON-A-BIKE  
(800) 531-2424**

# HELMET STOP REPORT FORM

This information may be presented to state and federal legislators as well as police or DOT administrators. The purpose is to ensure appropriate lawmaking and reasonable enforcement. Please provide as much detail as possible. Attach extra pages if necessary. Phone 1-800-347-1106 or 224-1106 in Portland if you have questions. Thank you for your cooperation.

PLEASE SEND TO: Sam Hochberg, A.I.M. Attorney, 750 Morgan Bldg, 720 S.W. Washington, Portland, OR 97205, ATTN: Gunny Hutch.

NAME: \_\_\_\_\_ ADDRESS: \_\_\_\_\_ CITY: \_\_\_\_\_

STATE: \_\_\_\_\_ ZIP: \_\_\_\_\_ PHONE: work \_\_\_\_\_ home \_\_\_\_\_

MAY WE USE YOUR NAME FOR LEGISLATIVE PURPOSES? YES / NO

## WHAT HAPPENED WHEN YOU WERE STOPPED?

DATE STOPPED: \_\_\_\_ / \_\_\_\_ / \_\_\_\_ TIME STOPPED: \_\_\_\_ : \_\_\_\_ a m / pm

LOCATION: \_\_\_\_\_

OFFICER NAME: \_\_\_\_\_ ID NO: \_\_\_\_\_ POLICE AGENCY \_\_\_\_\_

PRIMARY REASON FOR STOP: HELMET OTHER (specify) \_\_\_\_\_

CITATION? (YES) (NO) IF SO FOR: HELMET OTHER (specify) \_\_\_\_\_

CITE # \_\_\_\_\_ 1st appearance: \_\_\_\_ / \_\_\_\_ / \_\_\_\_ TIME: \_\_\_\_ : \_\_\_\_ am/pm

COURT LOCATION: city/county, \_\_\_\_\_

ANY OTHER CHARGES ISSUED AT THE SAME TIME? LIST: \_\_\_\_\_

IF THERE WERE ANY CRIMINAL CHARGES (not infractions), SPECIFY: \_\_\_\_\_

You should **IMMEDIATELY** obtain LEGAL ADVICE if you were so charged.

Did officer follow normal traffic laws in making the stop? YES / NO

If no explain: \_\_\_\_\_

Did officer treat you fairly and respectfully? YES / NO If no explain: \_\_\_\_\_

Was your helmet confiscated? YES / NO Explain: \_\_\_\_\_

Were you given an explanation on legal or illegal helmets? YES / NO  
If YES was the explanation? WRITTEN VERBAL BOTH

If verbal, describe: \_\_\_\_\_

### WHAT HAPPENED IN COURT?

Have you gone to court? NO When is court Date? \_\_\_\_\_

YES How did you plead? \_\_\_\_\_

If you pled guilty what was the fine?, \$ \_\_\_\_\_

If you pled NOT GUILTY, have you gone to trial?

NO When is your court date? \_\_\_\_\_

YES What was the verdict? GUILTY NOT GUILTY

If guilty, what was the sentence? \_\_\_\_\_

Briefly describe the evidence you presented at your trial (or include

a copy) \_\_\_\_\_

### DESCRIBE THE HELMET YOU WERE WEARING

BRAND: \_\_\_\_\_

MODEL: \_\_\_\_\_

When you bought the helmet did it have:

DOT sticker on the outside? YES NO

Label permanently fastened inside? YES NO

Was helmet modified? YES NO

If YES describe: \_\_\_\_\_

THIS PAGE SHOWS THAT IT PAYS TO GO TO A STATE BOARD MEETING, ESPECIALLY WHEN IT IS IN REDMOND, OREGON IN THE MONTH OF JUNE. THOSE WHO MISSED IT, MISSED IT, AND WE ALL PAY FOR THAT. SEE THE FUN HAD BY ALL! THANKS CENTRAL CHAPTER FOR THE GREAT FOOD AND HOSPITALITY. THE EDITOR, CAN YOU FIND WALDO?

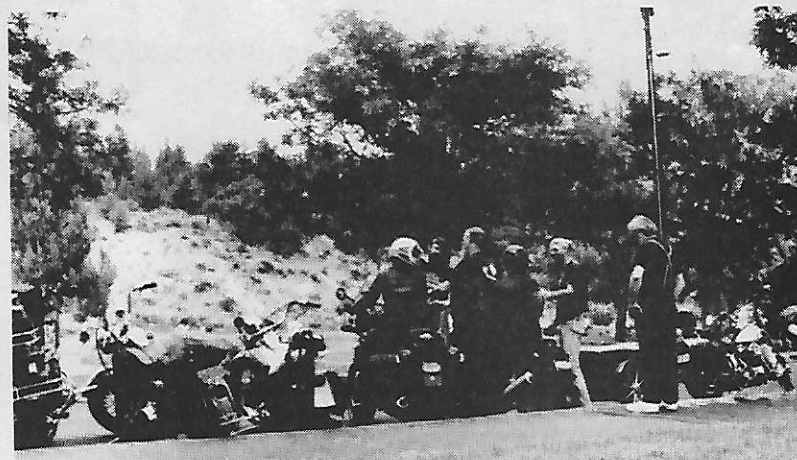



WHY ARE THESE PEOPLE SMILING?? IS IT BECAUSE THEY ARE OUTSIDE?? NOTT!!  
THEY ARE SOME OF YOUR STATE OFFICERS AND THIS IS WHAT THEY DO AT A NORMAL  
STATE BOARD MEETING ON THE NEXT PAGE. CAN YOU FIND WALDO IN TWO PICTURES??



REAL SERIOUS PEOPLE DOING SERIOUS WORK FOR YOU!

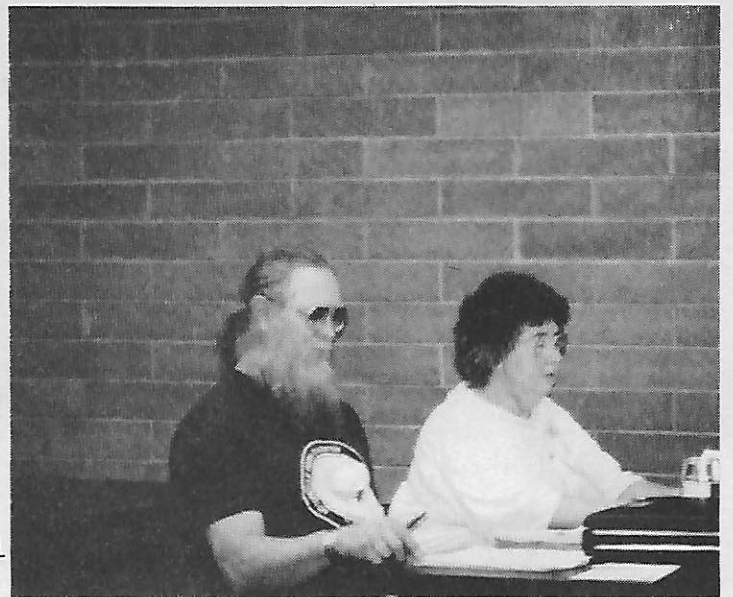
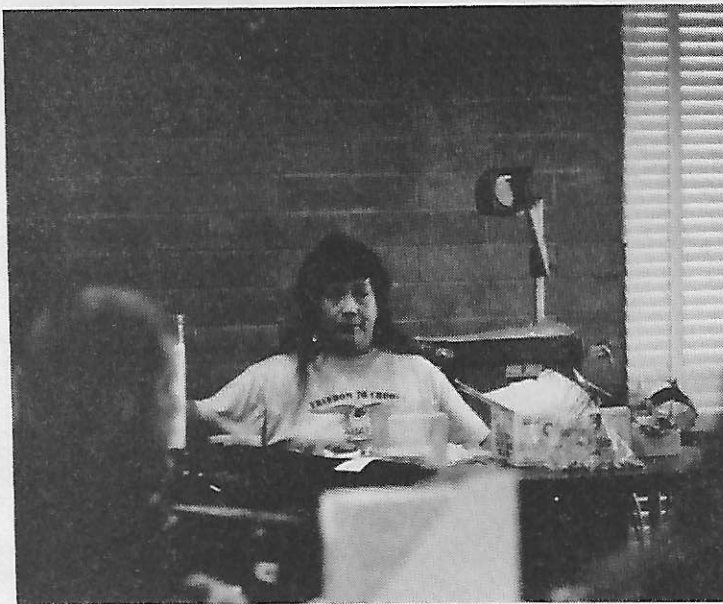
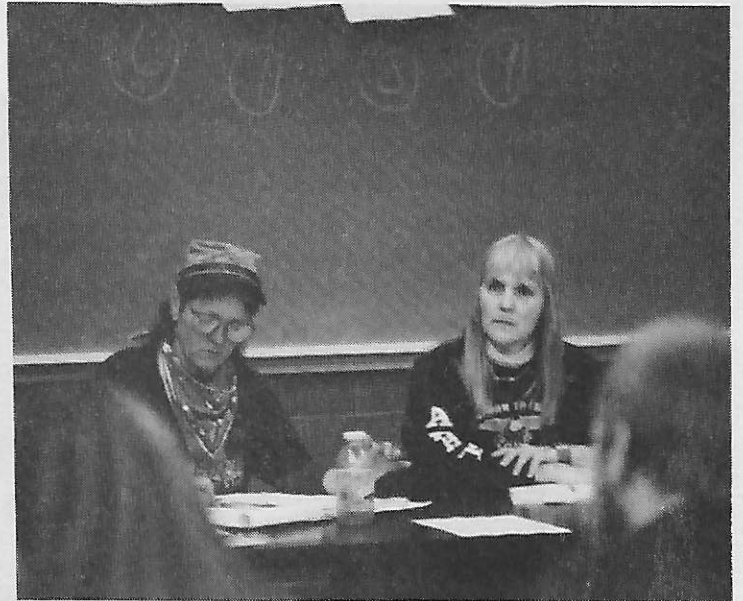
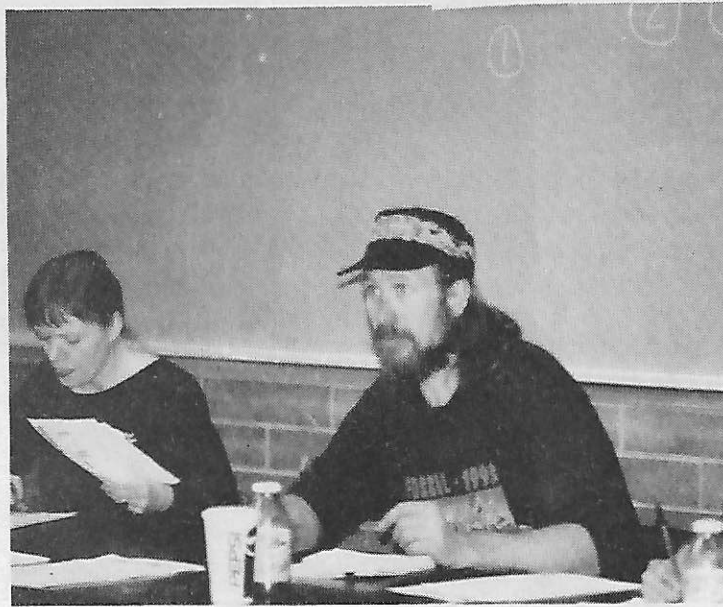



LINCOLN COUNTY'S VIEW OF FOSSIL '94'

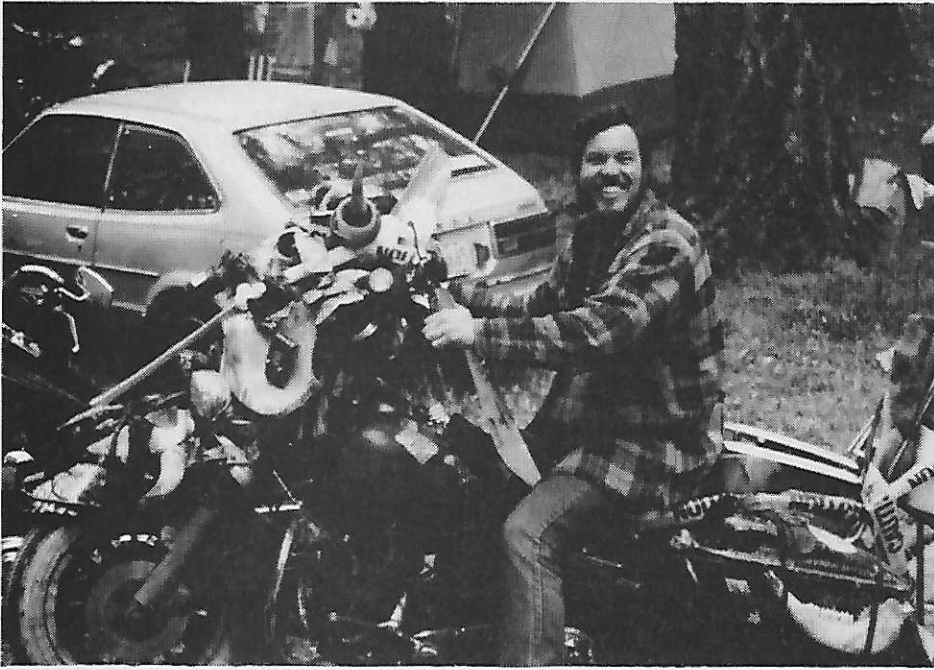

## FOSSIL 94

Fossil '94' was a big success I'm sure all of you that were there will agree, never could have happened without all that super help. People at the gate from Douglas Co. Chapter, a great job, lots of help makes things a lot easier for me. The games, what can I say? People are still talking about all the fun, you folks from Lincoln Co. sure made things happen.

Paramedics, right there when they were needed, very professional. Security, you guys worked very hard. I did not hear of any problems, seems you had a good hand on things. Folks that helped with details, wood, water, putting and tearing together. Angie did an excellent job on concessions. All that hammering and screwing that went on, we knew what to expect, a great stage, strong and sturdy. People selling ticket after ticket for that leather jacket, \$539.00 was donated to Fossil EMT's- jacket donated by one super guy, Jim owner of Columbia Motorcycle in Vancouver, Washington. I hope when you people go shopping over there you mention the jacket and how much we appreciate it.

The Fossil senior citizens made money to make things happen for their community too, they donated \$250.00 to Fossil pre school - \$750.00 to Fossil Legion, \$500.00 to Fossil ABATE Scholarship and \$2,072.00 to Fossil Senior Center they help people with food baskets and such and they had lots of fun too.

All in all what I'm trying to say is that without all of you that helped it would have never happened, give yourselves a huge pat on the back and a big applaud.

Thank you all, this is what working together as a team is all about and can make successful events.

Thanks Again,  
Rotten Roger

P.S. How about that music, was that good or was that good?!?!?! Thank you Randy.

## TO THE MEMBERSHIP

I'm confused. The simple everyday things are the most confusing. The obvious, no brainers.

Why when your rights and personal freedoms are being threatened and taken away daily would you opt to stay at home, watch the tube and generally act like you don't care. Why wouldn't you go to the meetings of and organization whose sole purpose is to enable you to protect your rights. Notice I said ENABLE not protect them for you.

Yes, I am afraid in addition to your membership fee it takes some actual effort on your part. You would need to come to the meetings to get information on the next new inroad the government is making to take away your right, as an American, to choose whether or not you want to ride a motorcycle. No, they will not stop with the helmet. They will not stop till it is illegal to ride or even own one.

The government has deep pockets to fund their fight against you. You and I should know this. We fill those pockets with our "contributions" from our paychecks.

So what's left? Your energy and participation in your local chapter. Anything you can do will help and be greatly appreciated by the few that are doing all the work now.

If you aren't registered to vote, do it! If you are registered, research the candidates and vote for the one who most parallels your own views and interests. Many issues that affect your life are run on the primary ballots. I can think of one in particular.

Become involved.

Signed Confused Jackson County

# hack'd

THE MAGAZINE  
FOR & ABOUT  
SIDECARISTS



P.O. Box 813  
Buckhannon, WV 26201

304-472-6146

Two weeks before Fossil Roger gets what (Mother) calls PFS, Pre Fossil Syndrome, and it does not get better, it gets worse. This year however, with all the problems that the week before the run brought, was not as bad as it could have been.

He stands tall and delegates and suggests and asks for help and people that have known him for years know that he would turn around and do the same, but most of all the causes- Motorcyclist Rights has always been 1st in his doings. I want to especially thank Roger for all I've learned from him and I know I'm not alone. When we got to the run site, where it was supposed to be Kinzua Air Park and we went to a lot of trouble and effort to get there, we make it all the way to the top and we could see how beautiful it could be. However, we went to bed and would worry about it tomorrow during daylight. Wrong, he could not sleep, he kept thinking and wishing for daylight so he could do something about it, why? Well his first concern was the people's safety, his concern was so serious, he would never put any one in jeopardy of any kind of danger and for this I want to thank all the people that were at Fossil, they showed us that they trusted that they were being thought of, had a wonderful time, I had a blast, I met some super neat people and added them to all of the rest of the neat people I've met throughout the years.

Again my respect and gratitude to Roger and all the wonderful people that helped every little bit that people helped with was appreciated.

Thank you all  
Angie Jensen

P.S. And by the way we still have Fossil '94' T-Shirts, short sleeves so if you were unable to get your shirt and would like to get one call me I'll make sure you get one \$10.00 plus \$1.50 postage. Call Angie at 503-285-4329 or write: ABATE of Oregon Inc., P.O. Box 4504, Portland, Oregon 97208, ATTN ANGIE.

## The A.I.M.ing Point

Greetings again Brothers and Sisters.

Wow !! This year has started with a bang. The Fossil run was a colossal success, even with all the hassle Rotten Roger had to go through with the sudden change of location. ROGER deserves our profound thanks for all the additional effort he put out to save the run. Thanks of course to everyone else involved in making this run one of the best I have attended. I've also read the comments from the residents of Fossil. I'm satisfied we are welcome in that town anytime.

I understand the Goldwing Rally in Kennewick, Wa. was a tough one because of wind and rain. However the OREGON STATE GWRRA RALLY at Sisters, was a real success. A gentleman by the name of Jim Kelty and his lovely wife Jean will be the new state Directors beginning in January, 1995. I'll get a complete list of officers and put it out before the first of the year. All bikes are welcome at GWRRA events, by the way. Lets support all the bike events we can. It's fun and makes us all look good. We all have our knees in the wind anyhow and as far as I'm concerned that's what its all about.. **BROTHERS AND SISTERS ON SCOOTERS.**

After Fossil, I left Portland on the 15th of June to ride to Redmond for the new Central Oregon Chapter A.B.A.T.E. meeting. We have to hand it to those folks. In just a few short months they have raised their membership to over 100. I have to tell you friends that is fast growth. If all motorcycle organizations in this state had that kind of growth we wouldn't have to worry about our legislators taking away our freedoms.

I want at this time to point out, particularly for my GWRRA and H.O.G. readers, that when I start to get political it is for **INFORMATIONAL** reasons **ONLY**. The only thing I want to influence is



**VOTER REGISTRATION.** Being in the minority, we have to use every tool we have or we won't be riding our bikes anywhere.

Much of this legislation of course is done in the interest of our safety, seeing as how we aren't smart enough to understand that people who ride motorcycles are either idiots or suicidal because motorcycles are dangerous. We can hide our heads in the sand but there are forces out in the world that would like nothing better than to see us **OFF** the road altogether because of the mistaken reasoning that when a motorcyclist is injured he or she becomes a **BURDEN ON SOCIETY**.

Statistics prove that theory is all wet but the public is going to believe what they want to believe. We simply must change our image for the better for our own sake.

We also need to get rid of the **MY BRAND IS BETTER SYNDROME** we all suffer with, and I'm just as guilty as you are. We all have our knees in the wind it doesn't matter what we ride. Uninformed **JOE PUBLIC** thinks we're all on Harleys anyhow so what's the difference. Almost any motorcycle you want to buy will cost as much or more than my first house did.

This fight isn't about helmets, or seatbelts, or where you can have a smoke, its way beyond that now. It's about the principles of freedom that this country was founded upon. This country is supposed to be **GOVERNMENT BY THE PEOPLE AND FOR THE PEOPLE, NOT GOVERNMENT TO THE PEOPLE,** the way it is now. The tail is wagging the dog and we as the voting public **MUST** to put a stop to it.

**ON A BRIGHTER NOTE:** There is a Regional **NATIONAL COALITION OF MOTORCYCLISTS (NCOM)** conference scheduled for the 7th through the 9th of October 1994 in Seattle. I'll let you all know as soon as I find out the exact location and lodging facilities. I urge **YOU ALL** to set aside the time and plan to be there. You will find it one of the

real eye-openers of these trying times we are experiencing in the biking world. Personally I come away from these meetings with informed people that really care about our lifestyle and sport ready to go to war to protect the few remaining freedoms we have in this country.

And on the light side, I have confirmation now from the good people at the Jantzen Beach Mall. They would like for all bikers and bike collectors to show off our bikes, inside the Mall where there is good security, the last weekend of January 1995. We still have some small details to work out, but we should have a good time showing all kinds of scooters and equipment working to upgrade our image as well. There will be an **A.B.A.T.E.**, **GWRRA**, and a **BIKEPAC** booth and any other interested motorcycle organization I can dig up will be there.

Rotten Roger is working with me through **A.B.A.T.E.** on insurance needs. This is my first attempt at organizing an event and his and everybody else's help is appreciated. It takes a lot of people to put these things together. From where I'm sitting we should have a great time and its happening during the sour time of the year for riding. I'll keep you posted as things develop.

Keep the round side down,  
**GUNNY HUTCH**

**AIM Chief of Staff for OREGON**



**SERVICE, PARTS AND ACCESSORIES  
FOR HARLEY DAVIDSON MOTORCYCLES**

**OPEN 9-6 M-F • 9-5 SAT**  
**693-1022**  
8200 E. MILL PLAIN BLVD.

**CUSTOM**  **CHROME**  



**SUNNY-SIDE UP  
DON'T FOLLOW ME...I'M LOST**

Pontius Pilate, Judea's notorious governor, stood eyeball to eyeball with Jesus of Nazareth. In the judicial process of interrogation, he heard Christ refer to "everyone who is of the truth, to which Pilate replied, What is truth?" That question hangs heavily on the thin wire of reason in many a mind this very hour. Pilate never waited for an answer. He whirled away in confused disgust. He should have stopped running and waited for the answer. Jesus could have told him that He alone had satisfying words of life...for He alone is "the way, the truth and the life" (John 14:6).

Christianity is not a system of human philosophy nor a religious ritual nor a code of moral ethics--it is the impartation of divine life through Christ. Apart from the Way there is no going...apart from the Truth there is no knowing... apart from the Life there is no living.

**God says...Be in Christ, rest yourself.**

Livin' on the "Sonny-side",  
Don Garino

**PARAMOUNT  
MOTORCYCLE SUPPLY**



1306 S.E. Court  
Pendleton, Oregon 97801

Sales: (503) 278-1644  
Service Dept.: (503) 278-0361

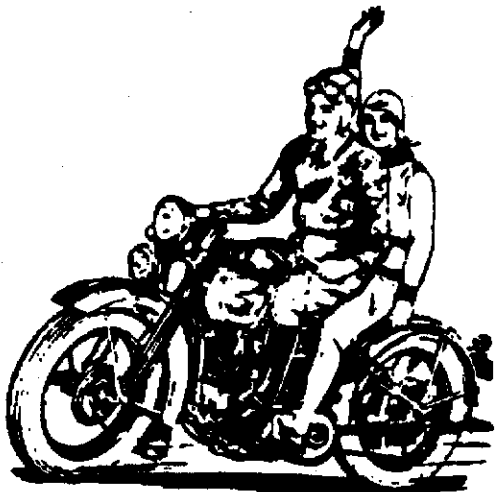

Re-printed from **AMERICAN  
MOTORCYCLIST** July 1994

**CUNA DOESN'T WANT YOU**

I recently received information from the CUNA Mutual Insurance Society, and I felt compelled to write them the following letter:

Recently, I received your offer of hospitalization accident insurance, based on my membership in the Kansas State University Federal Credit Union. I was seriously considering applying for the coverage until I read that you excluded coverage for injuries related to motorcycle riding.

I'm an avid motorcycle enthusiast and I've ridden for over 30 years. I do not consider my pursuit of this activity equivalent to the other exclusions listed: "participation in a riot, armed conflict, insurrection or war; a sickness or bodily or mental infirmity." I do not take illegal drugs or ride my motorcycle after consuming alcoholic beverages. You have taken direct aim at an activity that I love.

If, in fact, the members of the credit union own the credit union, and if the credit union can grant loans for the purchase of motorcycles (which I'm sure most are more than happy to do), how can the same organization deny medical coverage for simply participating in a legal and safe activity?

David G. Springer  
AMA No. 320479  
Manhattan, KS

If you would like to express your feelings about this exclusionary policy, write to: CUNA, Credit Union Members Insurance Services, Valley Forge, PA 19494-9990

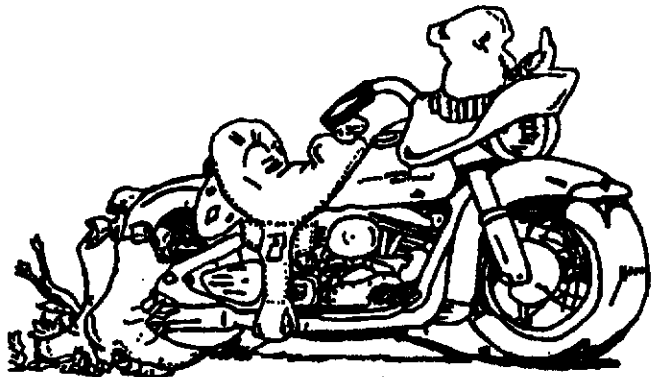

NEW OWNER  
OWNER  
SPARKY

HARLEYS ONLY

10%  
DISCOUNT  
FOR  
ABATE  
MEMBERS



- ★ SALES
- ★ ACCESSORIES
- ★ NEW & USED PARTS
- ★ CONSIGNMENT SALES

- ★ MOTOR AND TRANSMISSION SERVICE
- ★ INSURANCE ESTIMATES

OPEN 10 AM TO 6 PM  
MON THRU SAT

6212 NE KILLINGSWORTH  
PORTLAND, OR 97218  
(503) 282-7515

BikePAC of Oregon is YOUR political action committee in Salem. A PAC is the most effective way to promote YOUR interests to elected officials.

BikePAC listens to Oregon's riders and is currently working with the state legislature on: (1) enhancing Oregon's rider education program and motorist awareness, (2) fair and effective testing and licensing of motorcycle and moped operators, (3) fair insurance coverage for motorcyclists, (4) fair and reasonable access to recreational areas for off-road motorized activities and (5) adult freedom of choice on helmet use.

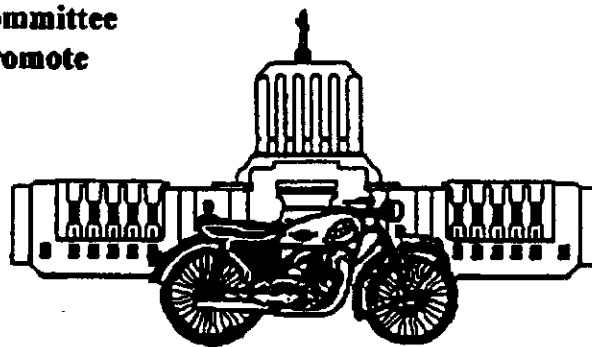

If these are your goals as well, join BikePAC.

"If you band together and talk as a group...they listen. An awful lot of riders don't belong to anything. They just ride for the heck of it. They don't recognize that somebody is protecting their freedoms. If you want to protect your rights, you've got to be active all the time."

-U.S. Senator Ben Nighthorse Campbell  
(D-Colo.)

PAC memberships/contributions (up to \$50 per person per year) are eligible for deduction from your Oregon State Tax Return.

## BikePAC of Oregon

P.O. Box 5612, Salem, Oregon 97304

Jack Fassel Executive Director (503) 650-9336	Butch Harbaugh Legislative Director (503) 838-1460	Steve Benson Secretary/Treasurer (503) 399-7514
---	--	---

I'm ready to join. Enclosed is  \$10 (single member)  \$15 (couple)

Please send more information about BikePAC of Oregon.

Name(s) \_\_\_\_\_

Street \_\_\_\_\_ City \_\_\_\_\_ Zip \_\_\_\_\_

Subj: Smokin' Jo  
Date: 94-03-05 21:17:53 EDT  
From: BMW K1

>From the BMW Club of Huston's newsletter, from the Central Cal BMW Riders' newsletter, from "The Intelligencer" submitted by Buddy Coft of Lubbock Texas (whew!)

### Smokers Rites

I think the war between the smokers and non-smokers is heating up a bit. I went into a restaurant for lunch the other day and, as is my practice, requested a table in the "no smoking" section. They seated me, and I went about the business of ordering and eating my food.

Somewhere between the clam chowder and a club sandwich, I caught the smell of nearby burning tobacco. Upon looking around, I noticed the man in the booth next to me smoking a freshly lit cigarette.

Overcoming my natural reticence regarding confrontation, I spoke to the man. "Excuse me, sir, but when you came in, did you ask to be seated in the no-smoking section?"

"Yes, I don't like the smell of smoke when I am eating any more than anyone else."

I asked, "Then why are you smoking that cigarette?"

"I've finished eating."

Silly me, it was obvious to the most casual observer.

I called the server over and made her aware of the situation. She pointed out to the man that he was smoking in a No Smoking section

(I suspect this was not a startling revelation) and went away with his assurance that he was just leaving.

Of course he didn't leave until he had finished that cigarette and lit another. But, at least he did finally go.

Apparently he had noticed the motorcycle helmet and jacket I was wearing when I came in, because in a minute or so, I noticed him eyeing the Harley parked by the front door. He took out a small notebook, wrote something on a leaf from it, tore off the note, and placed it between the seat and gas tank.

His next action took me completely off guard. He looked straight in the window at me, then put his foot against the gas tank and shoved the motorcycle over on its side. He then spun around and ran smack into a very large, bearded fellow who apparently owned the Harley.

That which ensued netted him at least one broken bone and hopefully a little jail time. After the police had come and gone, I helped the bearded gentlemen right his bike, and noticed the note the man had left. I unfolded it and read: "This will teach you to mess with smoker's rights."

I laughed and handed the note to the cigar-chewing biker. I then went around to the other side of the building, got on my BMW, and went back to work.

<b>FOR OFFICE USE ONLY</b> (All information treated confidentially.)	Referred by _____	Date _____
	MRF# _____	Exp. Date _____
	Member was given:	<input type="checkbox"/> Patch
		<input type="checkbox"/> Year Rocker
		<input type="checkbox"/> Pin

**It's time you did something to protect your rights!**  
**Join & Support the MOTORCYCLE RIDERS FOUNDATION so you can ride free in '93 and beyond.**

Annual Individual Membership.....\$20.00     Annual Sustaining Membership.....\$100.00  
 Annual Joint Membership....\$30.00     New Membership     Renewal Member#

---

*Please Print or Type*  
NAME \_\_\_\_\_ PHONE \_\_\_\_\_  
ADDRESS \_\_\_\_\_  
CITY \_\_\_\_\_ STATE \_\_\_\_\_ ZIP \_\_\_\_\_

Are you a member of a state motorcyclists' rights organization? Y / N Name \_\_\_\_\_  
What talents do you have that might benefit motorcyclists' rights and the MRF? \_\_\_\_\_

---

Will you volunteer these talents if the MRF needs your help? Y / N  
Mail with remittance to: **MOTORCYCLE RIDERS FOUNDATION • (202) 546-0983**  
Membership is not tax deductible **P.O. BOX 1808, Washington D.C. 20013-1808 • FAX (202) 546-0986**



# 1994 A.B.A.T.E. OF OREGON, INC. SANCTIONED RUNS

RUN DATE	EVENT	CHAPTER(s)	CONTACT & NUMBER
July 22-24	S.O.S. Run	Jackson County Douglas County	Gene&Lori Nelson 855-7345 Chris Vierra 498-2412
Aug.5, 6-7	Fox Creek Run	Salem	Ken or Gwen 363-7520 Mike or Ruby 769-7976
Aug. 13-14	Beaver Creek	Lincoln County	Vicki Lechner 563-3520
Aug. 19-21	Summer Run	N.E & S.E. Portland	Larry Shalk(S.E.) 774-2479
Sept.23,24,25	End of Summer Run	Washington Co. North Coast Yamhill Co.	Don Murray 648-9651 Don Smack 738-7156 Kraig 876-5135
October 14-16	Last Bash	State	Roger 285-4329
November ??	Toy Run	Washington County	Don Murry 648-4103
December 3	Shriner's Toy Run	Portland Chapters	Sarge 639-0873
December ??	Willamina Tree Of Giving	Yamhill County	Kraig Markusen 876-5135
December ??	Christmas Toy Run	Salem	Nic Oliver 394-3456

C:\ABATEMIS\RUNCALLST

This is all the information that I have that is current or all that's known to me. Please send in corrections or updates to the editor as soon as possible. I can only tell the readers what I know(which ain't much). If you know for real the information that is missing please contact by mail.

## OUT OF STATE RUNS AND OTHER NON ABATE RUNS

DATE:	EVENT	ORGINAZATION	CONTACT PERSON(S)
July 16	Poker Run	AMO Central Ore. Group	(503)548-4205/447-6158/ (503)389-7526
Sept. 9-10-11	Motorcycle Cruise-in	PETE	(503)632-6248

Please inform me as to any or all runs happening and I will see if I can print them here.

***INFORMATION IS THE KEY TO UNLOCK THE MYSTERIES IN LIFE. PASS ON THE KEYS SO OTHERS CAN UNLOCK SOME DOORS! OPEN YOUR MINDS TO NEW THOUGHTS.***

# FOSSIL GAME RESULTS

## PLANK RACE

1ST RUSTY TAYLOR 7.46SEC  
 2ND LYLE COYLE 6.15SEC  
 3RD BAD BOB 5.35SEC

## KEG RACE

1ST RANDY BECKER 2.84SEC  
 2ND CURT W. 3.46SEC  
 3RD LYLE COYLE 3.78SEC

## PING PONG BALL DROP

1ST RANDY BECKER/DEB FRYMAN  
 2ND MAILMAN  
 3RD KURT SPEAS/SHIRLEY

## OBSTACLE COURSE

1ST RANDY BECKER 4.79SEC  
 2ND MAILMAN 6.22SEC  
 3RD DON HAMLIN 7.54SEC

## BRONTO BOOT

1ST BAD BOB 45'6"  
 2ND RANDY BECKER 42'8"  
 3RD KRAIG JOHN MARKUSON 42'1"

## BLIND RACE

1ST CHICKEN(RUN OFF) 1'8"  
 2ND DAVE ALLYN(R\O) 1'0"  
 3RD BLUE/HED HEINES 0'21/2"

## SLOW RACE

1ST MAILMAN 34.63SEC  
 2ND GARY LECHNER 33.25SEC  
 3RD LYLE COYLE 33.09SEC

## WEENIE BITE

1ST MAILMAN  
 2ND MICHAEL/KARDYN COSKI  
 3RD SAM CALIFF/DARLENE HARRIS

## BIKE SHOW

### STOCK

1ST EASTMAN  
 2ND VERN ELWELL  
 3RD LEE SPAHR

### CUSTOM

1ST SPARKY  
 2ND GAIL GONZALEZ  
 3RD PAUL DUTRA

### RAT

1ST MILO  
 2ND GARY LECHNER  
 3RD RICK LOPATIN(?)

### PEOPLE'S CHOICE

1ST SPARKY  
 2ND GAIL GONZALEZ  
 3RD RICK LOPAD,

### BICYCLE SLOW RACE

1ST JOSE ARREOLA  
 2ND BRAD  
 3RD JACOB

### EGG TOSS

1ST JOSE/BRAD  
 2ND JEREMY/DANIEL  
 3RD ERIC/JIMMY

### LONGEST RIDER

RIP OF EASYRIDER

### LARGEST MRO

WASHINGTON STATE ABATE

### LARGEST INSTATE MRO

NE PORTLAND ABATE

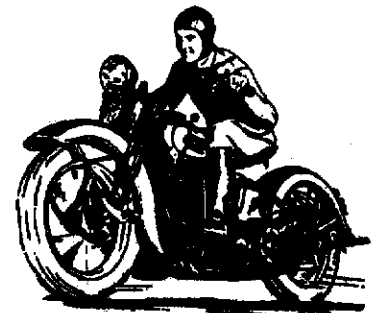
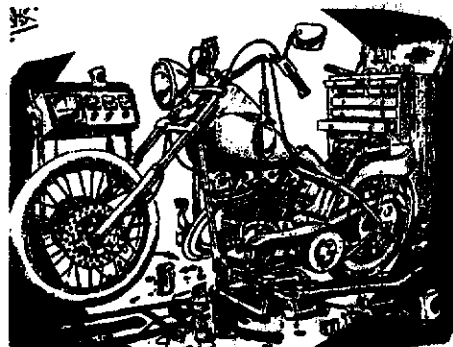
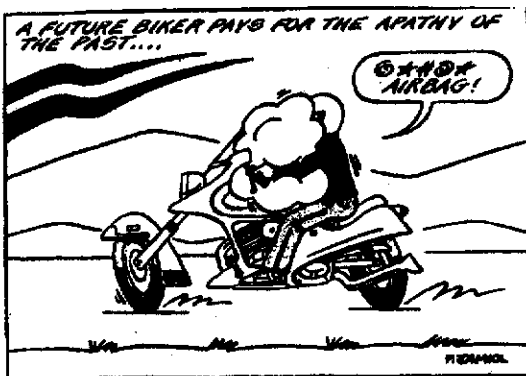



REPRINTED FROM MAY 3, 1994 OREGONIAN  
IN MY OPINION  
SECURITY COST NOT WORTH LIBERTY LOSS  
By PAUL dePARRIE

Benjamin Franklin warned, "Those who would trade liberty for security will have neither." How disappointed he would be to read our papers today and watch the public response-or lack of it- to the incursions of government powers into the liberties of the citizens all in the name of a war on drugs and gangs.

Recently we saw Chicago residents in the housing projects clamoring to surrender their Fourth Amendment rights to the government - all for the illusion of security. They were not only willing to give up their own rights against search and seizure, but everyone else's as well.

Instead of surrendering their liberty because of the tyranny of the gangs - and to the tyranny of the police - these people should be demanding their Second Amendment rights *en masse*. Government officials should help these citizens arm themselves and acquire firearms training.

Police cannot be everywhere. Nor can they provide security services for large groups of people.

The courts have repeatedly ruled that police have no obligation to protect anyone. And unless we can hire one officer for each citizen, it is foolish to expect them to take up such a task.

No, under the American system, each person (or household) is responsible for his own security. The police are only effective in arrests after a crime has been committed.

But, even more so, the American system incorporates a distinct distrust of police and other law enforcers. Our founders viewed government with suspicion.

There are glaring examples of a need to resurrect that suspicion today. We are altogether too trusting of authority.

Chicago is not an isolated incident. Nor was President Clinton's instant willingness to find a way to circumvent the Fourth Amendment.

Nationally, more and more drastic civil-rights abuses are being committed against citizens in the war against drugs and gangs - in the name of security. There has been the return of the "no-knock" and the "John Doe" search warrants - both of which we fought a revolution over some 200 years ago. "Telephonic" warrants, impossible to present or prove their existence at the time of the search, were recently introduced in Portland. Police are engaging

in these domestic home assaults wearing ski masks, making it impossible to identify them.

As appalling as this all is, there is one thing worse. It is the apathetic - even adoring - response of the American public.

Attorney General Janet Reno "takes full responsibility" for the deaths of 85 people in Waco, Texas, and her head does not roll at Clinton's order, nor does the public demand it. America surrounds Iraq for more than nine months waiting for sanctions (read:lack of supplies) to take their toll, but the same federal government cannot allow more than 51 days before fatigue and irritation caused its agents to incinerate men, women and children in the Branch Davidian compound. The public response: three cheers of Reno.

In Portland, residents wanting security from car theft are ready to surrender their Fourth Amendment rights with a sticker to allow their cars to be stopped late at night without probable cause.

"It's not a free ride," Police Chief Charles Moose tells us while explaining that the stops won't be limited to checking for stolen vehicles. The sticker, in other words, is automatic permission to search.

This mirrors the response of most Americans to these heinous constitutional breaches. "Do whatever you want. Violate everyone's rights. Demolish the Constitution, just make me be safe from the drug dealers and the gangs and let me watch 'Cops' on TV in peace."

Whatever happened to the Americans who defended their own liberty to the death? Whatever happened to people who looked out for their own neighborhoods instead of depending on the feds and City to take over our responsibilities?

It is one thing to work with the police; it is another to empower them to trample liberty in order to gain some sense of security.

If history tells us anything, it shows that once the government is allowed to trample one group's rights for a so-called good reason, the rights of others are not far behind. Franklin was right.

The question is whether Portlanders and all Americans will begin to be responsible for their own neighborhood, take the inordinate powers away from police, stop the use of troops in our neighborhoods and demand that those involved in such abuses be removed. The alternative is to have troops with submachine guns on nearly every corner to guarantee our safety.

Dear Editor,

When someone asks me what is ABATE and who are it's members, this is my answer: ABATE is a group of people who feel a kinship for each other because they're bikers and/or because they believe in personnel freedom. We are people who believe that we do not need the government running every aspect of our life. WE believe we should run the government, not the government running us. I believe most members would agree with my definition. After attending Fossil 1994 I really question if my description is true. Let me explain. I was at Fossil playing the very loud music. Now hang on, I realize that there has to be a balance between me playing loud music and other peoples right to peace and quiet. Yeah, Fossil is not a KOA. The problem I'm talking about is much bigger than that and certainly much more important. Let me explain. I saw Rich Benson just after the first of the year and he told me about the new Fossil location. He was excited and told me there was plenty of room for the speakers, if people didn't like the volume there was plenty of other places to camp. Well, we all know what happened to the new site. It didn't work and we were back to the old site and packed in tight. As we unloaded the stereo and set up camp I saw Rich. I told him I saw the problem and I was willing to work with people concerning the volume. He said have fun. Well the first night, security came up, said they had some complaints and to turn it down. I said I'm going to play two more songs and then I'll do that. After the songs we turned it off. The next day, about six o'clock Sergeant at Arms, Bear comes up and says turn it down now and turn it off at ten o'clock or you are out the front gate. Then he pushed me around camp with his belly. [that's another letter] Do you see the problem yet ??

Some of the people that enjoyed the music stopped by and said so. The problem is no one who was bothered by the music ever came by

to say so, instead they went to security. Is this the way you treat your neighbor, let alone a fellow biker? Don't walk over, discuss and state your complaint just call security. Let the organization take care of it, I can't take care of myself. Let the government do it for me. Does our government have us so molded and imprinted that we forget how to take care of ourselves? We can't go to our neighbor and try to take care of the problem, no we need some one to do it for us.

This reminds me of a man I met in Romania when I did some volunteer work there. He said before the revolution he could not walk down the street with an American without getting into trouble with the communist government and when he listened to Voice of America he had to turn the radio down very low, put his ear against the speaker, he feared his neighbor would turn him in or who might be listening in the hall. After the revolution he could walk the streets with me and also did not have to worry about who heard him listening to Voice of America. But once in awhile he would find himself with the radio turned down low and his ear against the speaker listening to America. He would think to himself, what the hell am I doing? I don't have to do this anymore! He said he still did it because it was ingrained in him, they had molded him. He had to work at breaking the habit.

Do we ABATE members also have to ask what the hell are we doing? Have we been imprinted and molded by the government to let them take care of our problems? It seemed so to me in Fossil. The difference between the Romanian and us is, at least he knew the government molded him.

I say, turn up your radio!!

Jeff McLaughlin

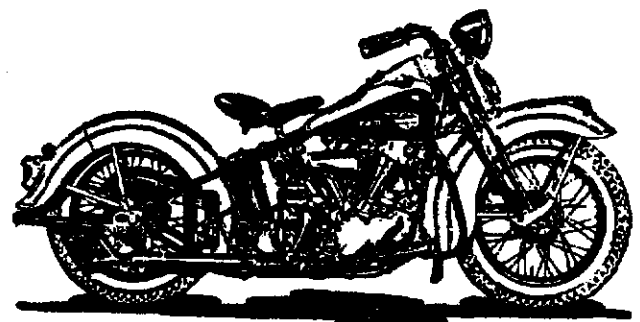

**ATTN: Members**

Following is a list of products available through ABATE of Oregon, Inc. Products are another way of helping support ABATE.

Revised: February 1994

**ABATE PRODUCTS ORDER FORM - PRICE LIST**

QTY.	PART NO.	DESCRIPTION	PRICE	TOTAL
<b>YEAR PINS</b>				
_____	AYP2	Year Pin - 2 yr. member - blue	3.00	_____
_____	AYP3	Year Pin - 3 yr. member - white	3.00	_____
_____	AYP4	Year Pin - 4 yr. member - red/black	3.00	_____
_____	AYP5	Year Pin - 5 yr. member - white/black	3.00	_____
_____	AYP6	Year Pin - 6 yr. member - black/orange	3.00	_____
_____	AYP7	Year Pin - 7 yr. member - black	3.00	_____
_____	AYP8	Year Pin - 8 yr. member - dark blue	3.00	_____
_____	AYP9	Year Pin - 9 yr. member - yellow	3.00	_____
_____	AYP10	Year Pin - 10 yr. member - red/white/blue	3.25	_____
_____	AYP11	Year Pin - 11 yr. member - purple/black	3.00	_____
_____	AYP12	Year Pin - 12 yr. member - blue/red	3.00	_____
_____	AYP13	Year Pin - 13 yr. member - green/black	3.00	_____
_____	AYP14	Year Pin - 14 yr. member - black/red	3.00	_____
_____	AYP15	Year Pin - 15 yr. member - gold/black	3.00	_____
_____	AYP16	Year Pin - 16 yr. member - grey/black	3.00	_____
_____	AYP17	Year Pin - 17 yr. member - copper/black	3.00	_____
_____	AYP18	Year Pin - 18 yr. member - light blue/gold	3.00	_____
_____	AYP19	Year Pin - 19 yr. member - purple/gold	3.00	_____
_____	AYP20	Year Pin - 20 yr. member - red/white/blue	3.75	_____

**ABATE PINS**

_____	ALAN	ABATE Anniversary Pin	3.25	_____
_____	ALPIG	ABATE Logo Pin - gold	5.00	_____
_____	ALPIS	ABATE Logo Pin - silver	5.00	_____
_____	ALPIP	ABATE Logo Pin - pewter	5.00	_____
_____	AEPIS	ABATE Eagle Pin - large, silver	5.00	_____
_____	AEPIG	ABATE Eagle Pin - large, gold	5.00	_____
_____	AWP	ABATE Wing Pin - silver	5.00	_____
_____	AWPG	ABATE Wing Pin - gold	5.00	_____
_____	ASP	ABATE Supporter Pin	4.00	_____
_____	AUWP	ABATE Uplifted Wing Pin - 5 color	4.00	_____
_____	ALOP	ABATE Oval Logo Pin - black/gold	4.00	_____
_____	A#1P	ABATE #1 Pin - small, 3 color	2.25	_____

**MISCELLANEOUS**

_____	AFRB	ABATE Freedom Of The Road Belt Buckle - pewter	15.00	_____
_____	ALH	ABATE Logo Hats - white on black	5.00	_____
_____	CW	Screw The Helmet pin	3.00	_____

**JEWELRY**

_____	AER	ABATE Logo Oval Earrings - black/gold, pair	5.50	_____
_____	AFP	Fossil Pin	3.75	_____

**ABATE T-SHIRTS**

_____	AFRTS	ABATE T-Shirts	10.00	_____
		Sm _____ Med _____ Lg _____ X-Lg _____		
_____	AFRTL	ABATE Sweatshirts	15.00	_____
		Sm _____ Med _____ Lg _____ X-Lg _____		

NOTE: Assorted Colors.....X-Lg and LARGER add \$2.00 Chapter Logo setup fee with each order (One time charge) 9.50 (In order to be able to obtain shirts at this price, orders must be a minimum of 12 shirts or more.)

QTY.	PART NO.	DESCRIPTION	PRICE	TOTAL
<b>SPECIAL ORDER ITEMS</b>				
_____	ANG	Year Bars (Indicate year _____ - 1982 thru 1993 available)	1.00	_____
_____	CLOTH	Year Bars (Indicate year _____) Small 1984-1993 avail.	1.00	_____
_____	CLOTH	Year Bars (Indicate year _____) Large 1984-1992 avail.	1.50	_____
_____		License Plate Frames - Cars w/Let Those Who Ride Decide	5.00	_____
_____		License Plate Frames - Motorcycles w/Let Those Who Ride Decide	5.00	_____

**ABATE PRODUCTS**  
**P.O. Box 4504**  
**Portland, Oregon 97208**  
**Angie Jensen, Products Director**  
**PHONE: 503-285-4329**

PREPAID \_\_\_\_\_ COD \_\_\_\_\_

DATE \_\_\_\_\_

NAME \_\_\_\_\_

PHONE NUMBER \_\_\_\_\_

ADDRESS \_\_\_\_\_

CITY \_\_\_\_\_ STATE \_\_\_\_\_

ZIP CODE \_\_\_\_\_

**Please use street address - we ship UPS where ever possible.**

**THANK YOU FOR YOUR ORDER!!**



# A.B.A.T.E. of Oregon's MEMBERSHIP CLASSIFIEDS

NOTE: All ABATE of Oregon members may run their ads FREE for 3 months. The date in parenthesis ( ) is the last month the ad will run in the newsletter.

**FOR SALE: 1954 Cushman COMPLETE**  
with paperwork from Albany Park and Rec. Dept.  
Garden Cart Type  
call (503) 563-2398  
ask for Randy or Deb  
(9-94)

Call Gordon at (503)253-7343 to place your classified with us Today!

♪Female Vocalist with Gigs♪  
NEEDS: GREAT Keyboard Player  
Rythum&Blues w/Country Rock  
(503)625-6019  
SERIOUS INQUIRIES ONLY  
(9-94)

FOR SALE: PROJECT BIKE  
67 TRIUMPH BONNVILLE  
CHOPPER  
IT RUNS, BUT NEEDS WORK  
ALSO  
60 MERCURY COMET 4 DR.  
RUNS AND DRIVES NEEDS TLC  
GOOD RESTORE PROJECT  
CALL SCOTT (503) 288-8570  
(8-94)

**FOR SALE:**  
*(for the right PARTY)*  
**(1) ROCKIN' BLUES BAND**  
**KENNY & the ALL-STARS**  
**SMOKIN' SAX AND DUELING**  
**GUITARS!**

WE PLAY RUNS, WEDDINGS,  
PARTIES, AND A.B.A.T.E.  
FUNCTIONS.

FOR BOOKINGS, INFO AND  
REFERENCES, CALL:  
KEN AND GWEN @  
(503) 363-7520 AFTERNOONS  
**P.S. KEEP THE WIND**  
**IN YOUR NOSE!**  
(7-94)

♪**Francine West**♪  
& The High Speed Wobblers♪  
For Hire  
ART (503)625-6019  
(7-94)

FOR SALE: 1980 Harley Sporster  
Limited edition  
Factory scroll work  
#434 out of 1,000  
NEW EVERYTHING!!!  
\$6,500.00 O.B.O  
Call Stoner(503)746-1393  
or J.J. (503)822-6142  
(9-94)

**FOR SALE - ABATE Memberships.**  
Anytime of the year. See inside back cover for details and application. Sign up a friend today!  
(Indefinitely)

**TOO MANY PROJECTS, NOT ENOUGH TIME!**

**FOR SALE:**  
1959 Chevy 4 Wheel Drive Pick-up  
Original running gear. Runs fine.  
\$2,000.00 or make offer.  
(503)563-3520  
Gary or Vicki Lechner  
(7-94)

**ABATE OF OREGON IS NOT RESPONSIBLE FOR ANYTHING SOLD THRU THESE ADS. THESE ARE THINGS THAT INDIVIDUALS ARE SELLING**  
**NOT ABATE OF OREGON.**  
**THE EDITOR 3-94**

**FOR SALE**  
**LIFE MEMBERSHIPS IN ABATE OF OREGON**  
**PRICE \$200.00**  
**INCLUDES LIFETIME NEWSLETTER AND LIFE MEMBER PATCH**  
**SEND YOUR CHECK TO STATE MEMBERSHIP SECRETARY PO BOX 4504, PORTLAND, OREGON 97208**

CI ABATEMENTS CLASSIFIED

Submit

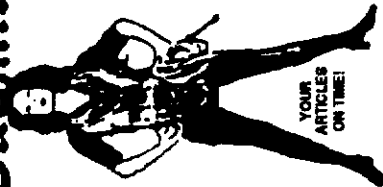

YOUR DEADLINE IS THE 15th OF EACH MONTH!!!



## From the Coordinator

Well because of deadline and printing schedules, this is a little late but, Happy Fourth of July. I hope it was a safe and enjoyable one for all of you. As patriotic citizens of this country, I hope that you took a little time from the parties and fireworks to reflect upon the roots of our nation. Thank goodness for what the founding fathers of this nation did for us. They set forth a new standard of government that would, as they intended, protect the rights of the people first. They wrote the greatest human rights document ever - The Bill of Rights. If you can find a copy of this great piece of work and read it. It should inspire us all and rekindle the lust for freedom that we all share. It will also help to remind us of what those early founders felt needed protecting. FREEDOM FOR FUTURE GENERATIONS. So what went wrong? Who's to say? Maybe the people just became complacent and apathy set in. Whatever the reason, I'm still thankful to the forefathers for their efforts.

Enough flag waving and on to what's happening. As you've probably heard by now Fossil was a great success. Commander Cody really rocked, hell we even shut down the ABATE info booth and had everyone dancing. We even had some little dark haired gal up on the table. (who was that?) If you didn't have fun you must have been dead. Thanks again to Rotten Roger for another terrific job.

Speaking of good jobs, I'd also like to thank all of those officers that took the time to write reports about their various trips for ABATE. That last newsletter was a nice piece of work.

It was our biggest issue ever,

and mostly information worth reading. Good job everyone. It is very satisfying to see how this organization just keeps getting better all the time. We've received some excellent press coverage from Fossil also. Things are definitely turning around and with the help of our people we can and will be successful in the future. It truly has become a cooperative effort.

July brings some of the best riding of the year and also some of the best times. On the 16th I will be at the Blue Mountain chapter's meeting. On the 22nd thru the 25th I'll be at the SOS Run at South Umpqua Falls. If you've never been there try to make it. This is one of the best runs I've ever attended anywhere, and definitely the best site you can imagine. Unfortunately this may be the last year at this site, because of the endangered species act. They are putting a fish hatchery on the river near there in an effort to bring back the steelhead that once were abundant in the river. So this may be your last chance at the great natural waterslide and the beautiful scenery in the area. Other than that it's been a little quiet. I guess everyone is just kind of relaxing after Fossil. I'll have a lot more to say in the next issue after I start getting around to the runs and meetings and such. Hope to see you out there. As you know, if I'm around and you need to address an issue about ABATE look me up at one of the functions and let's talk. All I ever ask is that when we have any discussions about ABATE business please let's do it straight. It eliminates misunderstandings and helps comprehension.

See ya's in the wind.....

Rich

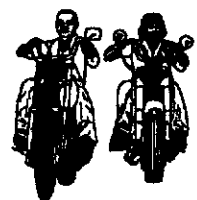
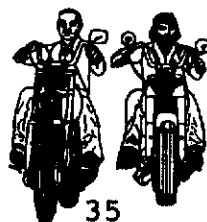
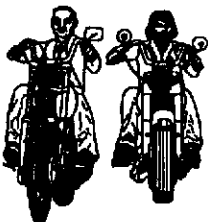

SEPTEMBER 10 1994

# BEAVER CREEK BUST



# MOTORCYCLE CRUISE-IN

A Great Destination for a Ride.

As in the past, the BEAVERCREEK BUST will have rides and activities for children, plenty of food, a beer garden, and local vendors displaying their crafts.

### Scheduled Events

<b>Friday</b> 6pm-Last Chance Saloon Open 8pm-11pm Johnny Limbo and the Logans	<b>Saturday</b> 7am-Sheep Dog Trials 12-5pm-Motorcycle Cruise in Approx. 10am-3pm "Silver" Classic Motorcycle / Car Auction 8pm-11:30pm McKenzie River Band	<b>Sunday</b> 8am-Sheep Dog Trials 8am-Horse play days (amateur western horseback competition) 9am-Morning service by Christian Motorcycle Association 10am-4pm-Custom / Classic Car Cruise-In & Show Approx 10am-3pm "Silver" Classic Car / Motorcycle Auction
--	---	---

All types of antique, modern, and custom motorcycles will be on display from 12 pm until 6:00 pm at which time 1st, 2nd and 3rd place prizes will be awarded for each class as picked by the audience. In case of rain, the display area will be moved into the "Big Tent".

Call Pete at (503) 632-6248 for motorcycle entry information and vendor tables.  
Show entry for motorcycles - Free. Vendor booths \$35.00  
Motorcycle campsites also available.

**A.M.O.**  
Central Oregon Group



**6th Annual  
July 16, 1994**



Bike Show  
Food  
Fun  
Games  
Music  
Camping

Sign in at OCHOCO CREEK PARK - Prineville  
9:00 am to 11:00 am

Entry Donation: \$10 advanced, \$12 day of the run  
\$5 kids 12-16, under 12 Free  
For Info Call 548-4205, 447-6158, 389-7526

7TH ANNUAL

# CONCHIP BOOZE

COWLITZ COUNTY ABATE

JULY 15,16,17TH 1994

FREE RUN PINS FOR THE FIRST 300

FOOD  
VENDORS MUST PRE-REGISTER  
30 DAYS IN ADVANCE

LIVE MUSIC  
FUN & GAMES

**ALL MAKES OF MOTORCYCLES WELCOME**

NO PETS, NO PRIVATE KEGS NO DISCHARGING OF FIREARMS  
MUST BE 21 YEARS OLD WITH ID

VENDORS, REFRESHMENTS, DOOR PRIZES, TROPHIES, RUN SHIRTS

ADMISSION:  
ALL ABATE MEMBERS: \$10.00  
NON MEMBERS: \$15.00

FOR MORE INFORMATION  
CALL: DUANE  
1-(206) 377-6269  
(IARY  
1-(206) 4238285

LOCATION:  
433 CLINE RD  
CASTLE ROCK WA  
98611

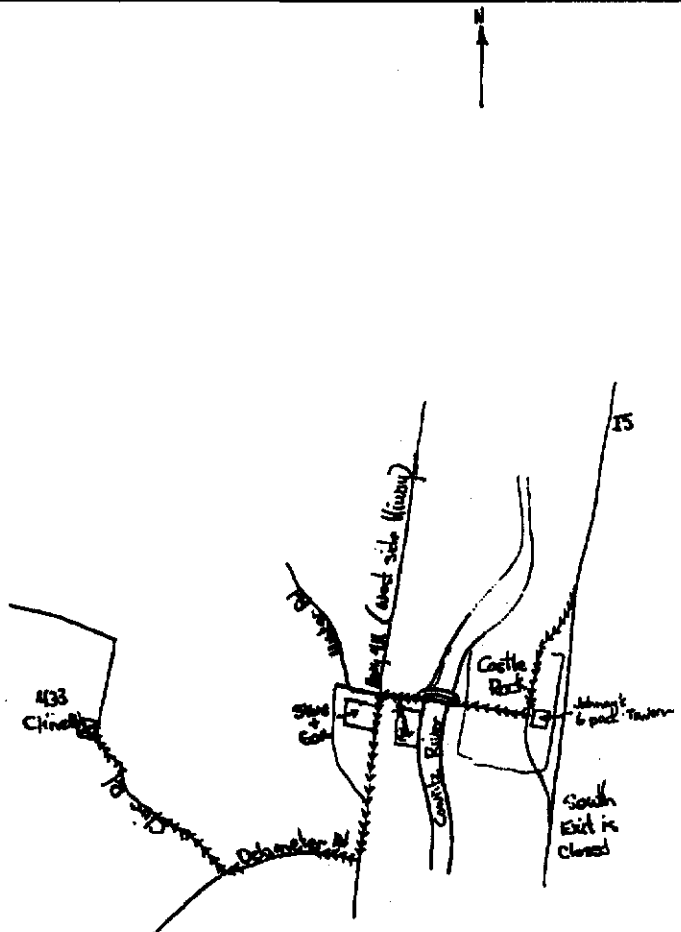



6<sup>TH</sup> ANNUAL

SOUTHERN OREGON SUMMER RUN

**JULY 22 • 23 • 24**  
AT SOUTH UNPQUA FALLS  
MAP ON BACK

LIVE MUSIC • BEER • T-SHIRTS  
BIKE GAMES • FOOD • CAMPING  
SWIMMING & LOTS OF FUN

**15 MEMBERS 20 NON-MEMBERS**

LIMITED VENDOR SPOTS — GENE 503-855-7515

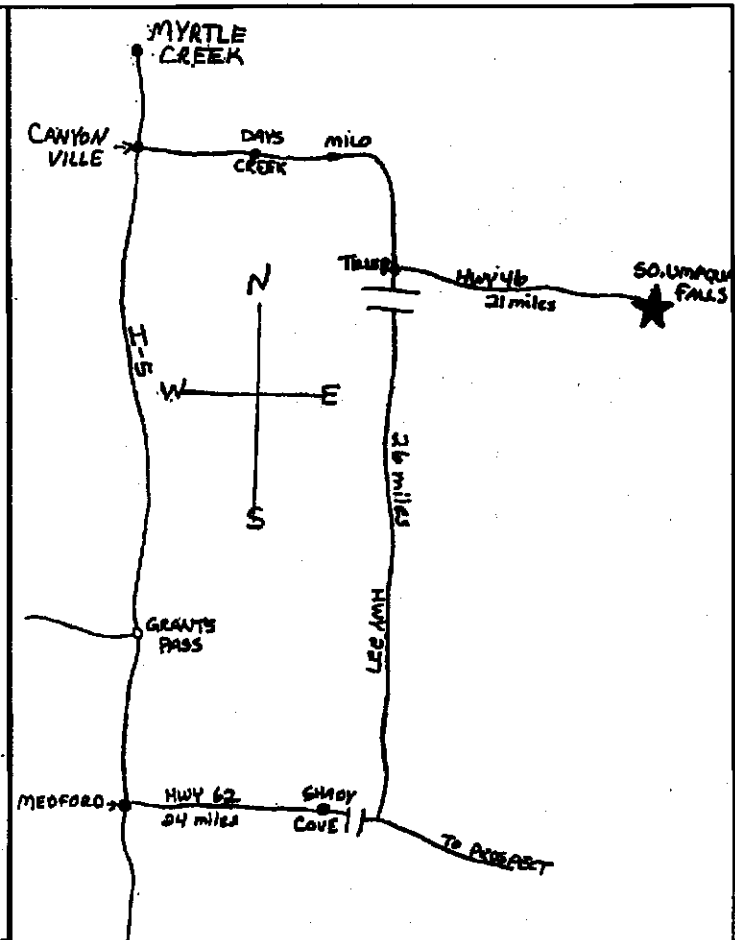

A.B.A.T.E. of SALEM PRESENTS

LIVE MUSIC RIGHT ON THE RIVER

THE FOX CREEK RUN '94  
FOX CREEK IS FREEDOM OF CHOICE

**AUGUST 5, 6, & 7**

\$10 Per Person Includes Gate, Camping & all the Fun.  
Gates Open at 3 p.m. Friday and Close at 10 p.m.  
B.Y.O.B. and Food and Beverages Available from a Wide Variety of Vendors.  
3 Miles South of Independence, Oregon

NO FIREWORKS, GUNS OR ATTITUDES. CONTAINED FIRES ONLY  
ALL DOGS ON LEASH, KIDS YOUR RESPONSIBILITY. HAVE FUN. 37

Contact: Ken or Gwen (503) 363-7520 Mike or Ruby (503) 769-7976

A.B.A.T.E. Lincoln County Chapter

**12th BEAVER CREEK RUN**

August 13 ~ 14 1994

Donation at Gate:  
Couples ~ \$5.00  
Singles ~ \$3.00

For Info: Vicki 563-8920

- Camping
- Food + Beverages Available
- LIVE MUSIC
- T-Shirts
- Dancing
- Drawing Prizes

Home Dogs on property Yours at your own risk!

No Firearms ~ No Fireworks ~ No Attitudes

ABATE OF OREGON PORTLAND CHAPTERS PRESENT FOR INFO CALL: LARRY (502) 774-2177

**SUMMER RUN 1994**



NO FIREARMS  
FIRES  
FIREWORKS  
PETS OR  
ATTITUDES

LIVE MUSIC  
FRIDAY AND  
SATURDAY

**AUGUST 19<sup>th</sup> 20<sup>th</sup> 21<sup>st</sup>**

SATURDAY  
BIKE GAMES  
SHOW TROPHIES

BRIGHTWOOD OR  
(MAP ON BACK)

CONCESSIONS  
FOOD & BEVERAGES  
T-SHIRTS  
PINS AND PATCHES  
AVAILABLE

ADVANCED TICKETS  
ENDS JULY 31<sup>ST</sup>  
ABATE MEMBERS \$10.25  
NON-MEMBERS \$15.00  
AT THE GATE  
MEMBERS \$15.25  
NON-MEMBERS \$20.00

ALL PROCEEDS GO TO  
MOTORCYCLE LEGISLATION  
AND SAFETY EDUCATION

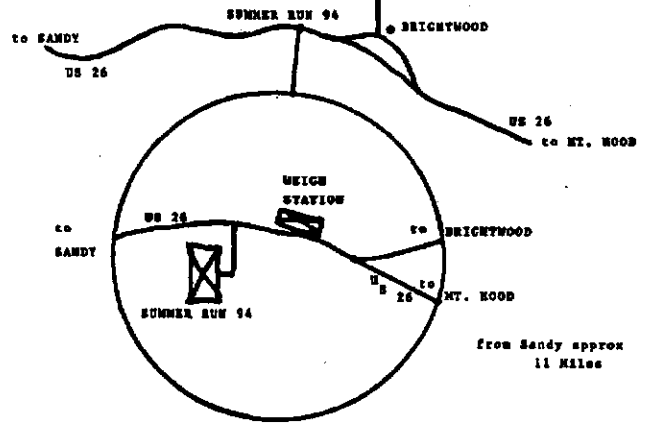

**Decide  
BEFORE  
You Ride.**



Don't be another statistic.  
**PLEASE, DON'T DRINK & RIDE!**

ABATE OF OREGON

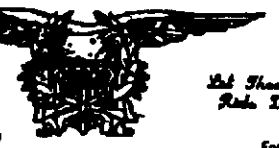

Let Those Who  
Ride Decide!

**6th Annual Tri-County  
END OF SUMMER RUN**

Sept 23, 24, 25 1994 at HORNING'S HIDEOUT

Approx. 7 Miles North of NORTH PLAMBE off  
Pumpkin Ridge Rd., on Brundage Canyon Rd.

For info:  
Washington Co. Chap.  
Dan Murray — 546-8651  
North Coast Chap.  
Don Brock — 738-7186  
Vanell Co. Chap.  
Kraig — 978-5135

VENDORS WELCOME  
\$50 Adv. Fee for All Weekend

BYOB — pop / Soft drinks excl.  
Vendor Food, Leather, Gen. Store

**BENEFITS**  
Fire OK, weather permitting  
Live Bands Sat. Night  
Fishing Available  
Swimming  
Paddle Boats  
Horse Shoes  
3 Kid's Playgrounds  
Deer Prizes  
Bike Games  
Bike Show  
50/50 Drawing(s)

**COSTS**

Member of MC	NON-Member
ADVANCE \$10.00	\$15.00
Gate \$15.00	\$20.00

Kids 12 & Under FREE (Kids' Dinner) 40 Acres of Camping + Room in Guest 200 Acres of Woods on a Dead End Road

**LIMITATIONS**  
The Gate will be Located at 11:00pm.  
No one will be allowed in or out, no Plan A, no Plan B, no Plan C.  
No Pets  
No Alcohol  
No Smoking

**THUNDER RIDE Sunday Morning  
to DJ's SWAP MEET (12 Miles)**

Come PARTY / Camp out WITH US before the SWAP MEET

Please abide by all wet limitations on your behalf. Please clean up all of your garbage, as your buddies don't have to.

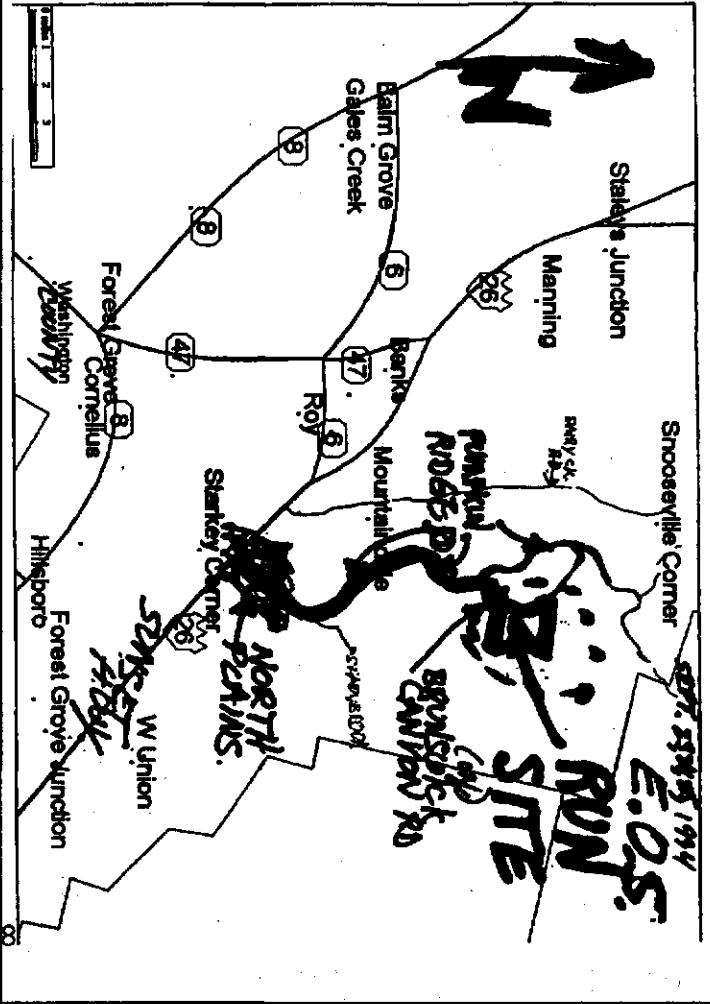



A.B.A.T.E. of Oregon, Inc.  
P.O. Box 4504  
Portland, OR 97208

ADDRESS CORRECTION REQUESTED

BULK RATE  
U.S. POSTAGE  
**PAID**  
PORTLAND, OREGON  
PERMIT No. 638

TIMELY DELIVERY REQUESTED  
DATED MATERIAL

4262 6/01/1995  
CRAIG BLAIR  
5410 SE PARK ST  
MILWAUKIE OR 97222-4597

\*D  
15\*



**BANG GO THE FIREWORKS, OUT GO THE SCHOOLS, WHEN YOU ARE RIDING, DON'T PLAY THE FOOLS. WATCH OUT FOR KIDDIES AND DRUNKS ON THE ROAD. YOU NEVER KNOW DEARS, THIS MESSAGE IS FOR YOU!!! DON'T DRINK AND RIDE. SEE YOU IN THE FUNNIES.**

### Chapter Meeting Places - Where & When

1st & 3rd SUNDAY	S.E. PORTLAND	12:00 Noon, The Pizza Baron, S.E. 122nd & Division, Portland
	JACKSON COUNTY	11:00 am, Oreagano's Pizza, 828 2nd Ave. Gold Hill
	BLUE MOUNTAIN	3:00 pm, Klondike Pizza, 828 Southgate, Pendleton
2nd SUNDAY	YAMHILL COUNTY	3:00 pm, Westward Ho, (3rd Street), McMinnville
3rd SUNDAY	SOUTH COAST	11:00 am, Gino's Pizza, 1324 Virginia Street, North Bend
	DOUGLAS COUNTY	11:00 am, Round Table Pizza, Roseburg Valley Mall, Roseburg
2nd & 4th SUNDAYS	COLUMBIA RIVER	12:30 pm, Cactus Club & Diner, 8131 N. Denver, Portland
2nd & 4th MONDAY	SALEM	7:00 pm, Pietro's Pizza, 1637 Hawthorne Ave. NE, Salem
2nd & 4th TUESDAY	WASHINGTON COUNTY	8:00 pm, Round Table Pizza, 2473 N.W. 185th, Beaverton
1st & 3rd WEDNESDAY	NORTH COAST ABATE	7:00pm, The Pizza Harbor, Seaside
	N.E. PORTLAND	7:30 pm, Izzy's Pizza, 1307 N.E. 102nd, Portland
3rd WEDNESDAY	CENTRAL OREGON	7:00 pm The American Legion Hall, 8th St., Redmond
1st & 3rd FRIDAY	LINCOLN COUNTY	7:30 pm, Moby Dick's Restaurant, Newport